

**SECTION 13**  
**Below the Hook Lifting**

<b>BALE LIFTING TONG</b> .....	13-14	<b>LIFTERS</b>		<b>PIPE</b>	
<b>BARRIER GRABS</b> .....	13-13-14	C-Hook, Custom.....	13-9	Carrier .....	13-14
<b>BEAM TONGS</b> .....	13-14	C-Hook, Plate Style.....	13-6-8	<b>PULLER, FORM PIN</b> .....	13-15
<b>BEAM, SPREADER</b>		Coil .....	13-12	<b>RAIL TONGS</b> .....	13-14
Adjustable.....	13-4	Container.....	13-15-16	<b>SHEET LIFTERS</b>	
Custom .....	13-5	Sheet .....	13-11	Custom .....	13-11
Fiberglass.....	13-4	Crane Forks.....	13-10-11	Telescoping.....	13-11
Fixed .....	13-3	Vacuum .....	13-16-18	<b>SLAB TONGS</b> .....	13-14
<b>BEAMS, LIFTING</b>		<b>LIFTING, BELOW-THE-HOOK</b>		<b>SPREADER BEAM</b>	
Adjustable Hook.....	13-1	ANSI Safety/Standard .....	13-4	Adjustable.....	13-4
Custom.....	13-5	Beams .....	13-1-5	Fiberglass.....	13-4
Fixed Hook.....	13-1	Bulky, Odd Shaped Objects .....	13-22	Fixed .....	13-3
How to Specify a Beam.....	13-2	C-Hook Lifters .....	13-6-9	<b>SUSPENDED PERSONNEL</b>	
Load Leveler .....	13-2	Coil Lifters .....	13-12	<b>PLATFORMS</b> .....	13-22
Twin Bail.....	13-2	Container Lifters.....	13-15-16	<b>TEA CUP CARRIER</b> .....	13-14
Twin Basket Sling .....	13-3	Crane Forks.....	13-10-11	<b>TONGS, LIFTING</b>	
<b>CARRIER, PIPE</b> .....	13-14	Flip-Rite.....	13-22	Barrier Grabs.....	13-13-14
<b>C-HOOK LIFTERS</b>		Load Indicator Devices .....	13-22-23	Beam Tongs .....	13-14
Custom.....	13-9	Magnets.....	13-18-21	Custom Tong Grabs .....	13-13
Plate Style.....	13-6-8	Material Handling System .....	13-22	Rail Tongs .....	13-14
<b>COIL LIFTERS</b>		Pin Puller.....	13-15	Slab Tongs .....	13-14
Custom Narrow Aisle .....	13-12	Pipe Carrier.....	13-14	Tong Grabs.....	13-13
Dixon Coil Grab.....	13-12	Sheet Lifters .....	13-11	<b>VACUUM LIFTERS</b>	
Dixon Coil Hook .....	13-12	Suspended Personnel Platforms.....	13-22	Advantages and Applications .....	13-18
Narrow Aisle.....	13-12	Tongs.....	13-13-14	Features of Vacuum Lifters .....	13-16
<b>CONTAINER LIFTERS</b> .....	13-15-16	Vacuum Lifters .....	13-16-18	Selection Guide.....	13-17-18
<b>CRANE FORKS</b>		<b>LOAD INDICATOR DEVICES</b> .....	13-22-23	Technical and Operation	
Adjustable.....	13-10	<b>MAGNETS LIFTING</b>		Information.....	13-16-17
Custom .....	13-11	A.C. Powered.....	13-20		
Fixed .....	13-10	Battery Powered.....	13-20-21		
<b>FORKS, CRANE</b>		D.C. Powered.....	13-19		
Adjustable.....	13-10	Permanent Lift.....	13-18-19, 13-21		
Custom .....	13-11	<b>MATERIAL HANDLING SYSTEM</b>			
Fixed .....	13-10	Beams .....	13-1-5		
<b>FORM PIN REMOVER</b> .....	13-15	Bulky, Odd Shaped Objects .....	13-22		
		Flip-Rite.....	13-22		
		Load Indicator Devices .....	13-22-23		
		Magnets.....	13-18-21		
		Pin Puller.....	13-15		
		Pipe Carrier.....	13-14		
		Sheet Lifters .....	13-11		
		Tongs.....	13-13-14		



## Lifting Beams

### Model AHB - Adjustable Hook Lifting Beam

The Adjustable Hook Lifting Beam is an ideal solution for lifting off center loads or varying load lengths where headroom is critical.

Top and bottom flange stiffeners are added to strengthen the beam laterally in case of side-ward movement caused by shifting of the load.

All lifters are proof tested exceeding ANSI/ASME B30.20 standards and test certificate issued. Painted safety yellow and clearly marked on both sides with rated capacity to conform to OSHA standards.

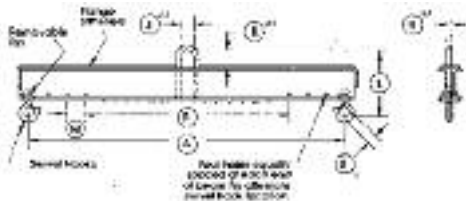

- Maximum stock diameter refers to the size of material that will fit into the swivel hook opening.
- All loads must be centered under the lifting bail.
- Please verify that the lifting bail size will suit crane hook.
- Other capacities and lengths available upon request.

Capacity <sup>4</sup> (lbs)	Length (in)		Total Height (in)	Hook Space (in)	Bail Size <sup>2,3</sup> (in)			Max. Stock Dia. (in)	Approx. Lifter Wt. (lbs)	Model Number
	A	B			H	J	K			
1,000	36	12	11-1/2	4	3/4	2	4	1-1/32	42	AHB-1-36-12
1,000	60	24	11-1/2	6	3/4	2	4	1-1/32	67	AHB-1-60-24
1,000	72	36	11-1/2	6	3/4	2	4	1-1/32	80	AHB-1-72-36
1,000	96	48	12-1/2	8	3/4	2	4	1-1/32	123	AHB-1-96-48
1,000	120	48	12-1/2	12	3/4	2	4	1-1/32	148	AHB-1-120-48
2,000	36	12	12-1/2	4	3/4	2	4	1-1/32	50	AHB-2-36-12
2,000	60	24	12-1/2	6	3/4	2	4	1-1/32	78	AHB-2-60-24
2,000	72	36	13-1/2	6	3/4	2	4	1-1/32	111	AHB-2-72-36
2,000	96	48	13-1/2	8	3/4	2	4	1-1/32	145	AHB-2-96-48
2,000	120	48	14-1/2	12	3/4	2	4	1-1/32	207	AHB-2-120-48
4,000	48	24	14	4	1	2	4	1-1/16	82	AHB-4-48-24
4,000	72	36	15	6	1	2	4	1-1/16	132	AHB-4-72-36
4,000	96	48	16	8	1	2	4	1-1/16	201	AHB-4-96-48
4,000	120	48	17	12	1	2	4	1-1/16	279	AHB-4-120-48
6,000	48	24	17-3/4	4	1-1/2	4	6	1-1/16	135	AHB-6-48-24
6,000	72	36	17-3/4	6	1-1/2	4	6	1-1/16	180	AHB-6-72-36
6,000	96	48	18-3/4	8	1-1/2	4	6	1-1/16	258	AHB-6-96-48
6,000	120	48	19-3/4	12	1-1/2	4	6	1-1/16	358	AHB-6-120-48
8,000	60	36	21	6	1-1/2	4	8	1-7/32	177	AHB-8-60-36
8,000	96	48	22	8	1-1/2	4	8	1-7/32	294	AHB-8-96-48
8,000	120	48	22	12	1-1/2	4	8	1-7/32	359	AHB-8-120-48
8,000	144	72	25-7/8	18	1-1/2	4	8	1-1/2	618	AHB-8-144-72
10,000	96	48	27-7/8	8	1-3/4	4	10	1-1/2	436	AHB-10-96-48
10,000	120	48	27-7/8	12	1-3/4	4	10	1-1/2	551	AHB-10-120-48
10,000	180	72	29-3/4	18	1-3/4	4	10	1-1/2	1,085	AHB-10-180-72
10,000	240	132	32-3/4	18	1-3/4	4	10	1-7/8	1,572	AHB-10-240-132
15,000	96	48	30-1/8	8	1-3/4	5	10	1-7/8	588	AHB-15-96-48
15,000	120	48	30-1/8	12	1-3/4	5	10	1-7/8	750	AHB-15-120-48
15,000	180	72	33-1/8	18	1-3/4	5	10	1-7/8	1,213	AHB-15-180-72
15,000	240	132	36-1/8	18	1-3/4	5	10	1-7/8	1,977	AHB-15-240-132
20,000	96	48	33-1/8	8	1-3/4	5	10	1-7/8	735	AHB-20-96-48
20,000	120	48	33-1/8	12	1-3/4	5	10	1-7/8	875	AHB-20-120-48
20,000	180	72	36	18	1-3/4	5	10	1-7/8	1,515	AHB-20-180-72
20,000	240	132	36	18	1-3/4	5	10	1-7/8	1,969	AHB-20-240-132
40,000	120	48	46	12	1-3/4	6	18	2-1/2	1,032	AHB-40-120-48
40,000	180	72	46	18	1-3/4	6	18	2-1/2	1,829	AHB-40-180-72
40,000	240	132	46	18	1-3/4	6	18	2-1/2	2,719	AHB-40-240-132
60,000	120	48	50-1/2	12	2	6	18	3-3/8	1,447	AHB-60-120-48
60,000	180	72	50-1/2	18	2	6	18	3-3/8	2,328	AHB-60-180-72
60,000	240	132	50-1/2	18	2	6	18	3-3/8	3,336	AHB-60-240-132

### Model FHB - Fixed Hook Lifting Beam

The Fixed Hook Lifting Beam is an ideal solution for lifting loads where headroom is critical.

Top and bottom flange stiffeners are added to strengthen the beam laterally in case of side-ward movement caused by shifting of the load.

All lifters are proof tested exceeding ANSI/ASME B30.20 standards and test certificate issued. Painted safety yellow and clearly marked on both sides with rated capacity to conform to OSHA standards.

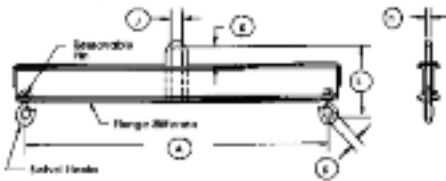

- Maximum stock diameter refers to the size of material that will fit into the swivel hook opening.
- All loads must be centered under the lifting bail.
- Please verify that the lifting bail size will suit crane hook.
- Other capacities and lengths available upon request.

Capacity <sup>4</sup> (lbs)	Length (in)		Total Height (in)	Bail Size <sup>2,3</sup> (in)			Max Stock <sup>1</sup> Dia. (in)	Approx. Lifter Wt. (lbs)	Model No.
	A	L		H	J	K			
1,000	36	11-1/2	11-1/2	3/4	2	4	1-1/32	47	FHB-1-36
1,000	60	11-1/2	11-1/2	3/4	2	4	1-1/32	74	FHB-1-60
1,000	72	11-1/2	11-1/2	3/4	2	4	1-1/32	87	FHB-1-72
1,000	96	12-1/2	12-1/2	3/4	2	4	1-1/32	136	FHB-1-96
1,000	120	12-1/2	12-1/2	3/4	2	4	1-1/32	168	FHB-1-120
2,000	36	12-1/2	12-1/2	3/4	2	4	1-1/32	56	FHB-2-36
2,000	60	12-1/2	12-1/2	3/4	2	4	1-1/32	88	FHB-2-60
2,000	72	13-1/2	13-1/2	3/4	2	4	1-1/32	121	FHB-2-72
2,000	96	13-1/2	13-1/2	3/4	2	4	1-1/32	158	FHB-2-96
2,000	120	14-1/2	14-1/2	3/4	2	4	1-1/32	227	FHB-2-120
4,000	48	14	14	1	2	4	1-1/16	88	FHB-4-48
4,000	72	15	15	1	2	4	1-1/16	142	FHB-4-72
4,000	96	16	16	1	2	4	1-1/16	214	FHB-4-96
4,000	120	17	17	1	2	4	1-1/16	299	FHB-4-120
6,000	48	17-3/4	17-3/4	1-1/2	4	6	1-1/16	128	FHB-6-48
6,000	72	17-3/4	17-3/4	1-1/2	4	6	1-1/16	178	FHB-6-72
6,000	96	18-3/4	18-3/4	1-1/2	4	6	1-1/16	256	FHB-6-96
6,000	120	19-3/4	19-3/4	1-1/2	4	6	1-1/16	355	FHB-6-120
8,000	60	21	21	1-1/2	4	8	1-7/32	175	FHB-8-60
8,000	96	22	22	1-1/2	4	8	1-7/32	292	FHB-8-96
8,000	120	22	22	1-1/2	4	8	1-7/32	356	FHB-8-120
8,000	144	25-7/8	25-7/8	1-1/2	4	8	1-1/2	610	FHB-8-144
10,000	96	27-7/8	27-7/8	1-3/4	4	10	1-1/2	437	FHB-10-96
10,000	120	27-7/8	27-7/8	1-3/4	4	10	1-1/2	543	FHB-10-120
10,000	180	29-3/4	29-3/4	1-3/4	4	10	1-1/2	1,069	FHB-10-180
10,000	240	32-3/4	32-3/4	1-3/4	4	10	1-7/8	1,556	FHB-10-240
15,000	96	30-1/8	30-1/8	1-3/4	5	10	1-7/8	584	FHB-15-96
15,000	120	30-1/8	30-1/8	1-3/4	5	10	1-7/8	745	FHB-15-120
15,000	180	33-1/8	33-1/8	1-3/4	5	10	1-7/8	1,192	FHB-15-180
15,000	240	36-1/8	36-1/8	1-3/4	5	10	1-7/8	1,961	FHB-15-240
20,000	96	33-1/8	33-1/8	1-3/4	5	10	1-7/8	702	FHB-20-96
20,000	120	33-1/8	33-1/8	1-3/4	5	10	1-7/8	861	FHB-20-120
20,000	180	36	36	1-3/4	5	10	1-7/8	1,499	FHB-20-180
20,000	240	36	36	1-3/4	5	10	1-7/8	1,958	FHB-20-240
40,000	120	46	46	1-3/4	6	18	2-1/2	1,034	FHB-40-120
40,000	180	46	46	1-3/4	6	18	2-1/2	1,859	FHB-40-180
40,000	240	46	46	1-3/4	6	18	2-1/2	2,738	FHB-40-240
60,000	120	50-1/2	50-1/2	2	6	18	3-3/8	1,425	FHB-60-120
60,000	180	50-1/2	50-1/2	2	6	18	3-3/8	2,378	FHB-60-180
60,000	240	50-1/2	50-1/2	2	6	18	3-3/8	3,384	FHB-60-240

**Below the Hook Lifting**

**Lifting Beams**

**Model TBB - Twin Bail Beam For Two Hoist**

The Twin Bail Beam is an ideal solution for utilizing two hoists to increase lifting capacity. The roller bearing swivel hook allows the load to be rotated at the next manufacturing location and pivots to prevent binding when one end of the beam is raised or lowered more rapidly than the other.

Top and bottom flange stiffeners are added to strengthen the beam laterally in case of sideward movement caused by shifting of the load.

All lifters are proof tested exceeding ANSI/ASME B30.20 standards and test certificate issued. Painted safety yellow and clearly marked on both sides with rated capacity to conform to OSHA standards.

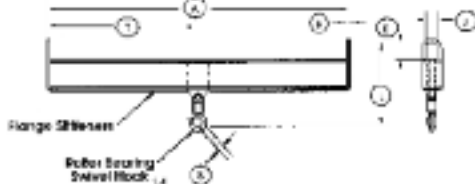

- 1 Maximum stock diameter refers to the size of material that will fit into the swivel hook opening.
- 2 All loads must be centered under the lifting bail.
- 3 Please verify that the lifting bail size will suit crane hook.
- 4 Can be supplied with roller bearing swivel hook or standard swivel hook.
- 5 Other capacities and lengths available upon request.

Capacity <sup>4</sup> (lbs)	Length (in)	Total Height (in)	Bail Size <sup>2,3</sup> (in)			Max. Stock <sup>1,5</sup> Dia. (in)	Approx. Lifter Wt. (lbs)	Model No.
			A	L	H J K			
4,000	72	21-7/16	1 x 2 x 4			1-11/32	164	TBB-4-72
4,000	96	22-7/16	1 x 2 x 4			1-11/32	239	TBB-4-96
4,000	120	23-7/16	1 x 2 x 4			1-11/32	326	TBB-4-120
6,000	72	24-7/16	1 x 4 x 6			1-11/32	202	TBB-6-72
6,000	96	25-7/16	1 x 4 x 6			1-11/32	291	TBB-6-96
6,000	120	26-7/16	1 x 4 x 6			1-11/32	372	TBB-6-120
8,000	60	28-15/16	1 x 4 x 8			1-11/16	206	TBB-8-60
8,000	96	29-15/16	1 x 4 x 8			1-11/16	327	TBB-8-96
8,000	120	29-15/16	1 x 4 x 8			1-11/16	391	TBB-8-120
8,000	144	32-15/16	1 x 4 x 8			1-11/16	644	TBB-8-144
10,000	96	34-15/16	1 x 4 x 10			1-11/16	482	TBB-10-96
10,000	120	34-15/16	1 x 4 x 10			1-11/16	583	TBB-10-120
10,000	180	34-15/16	1 x 4 x 10			1-11/16	1,099	TBB-10-180
10,000	240	37-15/16	1 x 4 x 10			1-11/16	1,599	TBB-10-240
15,000	96	38-1/8	1-1/4 x 5 x 10			2-1/16	632	TBB-15-96
15,000	120	38-1/8	1-1/4 x 5 x 10			2-1/16	793	TBB-15-120
15,000	180	41-1/8	1-1/4 x 5 x 10			2-1/16	1,248	TBB-15-180
15,000	240	44-1/8	1-1/4 x 5 x 10			2-1/16	2,017	TBB-15-240
20,000	96	44-3/32	1-1/2 x 5 x 10			2-1/4	857	TBB-20-96
20,000	120	44-3/32	1-1/2 x 5 x 10			2-1/4	993	TBB-20-120
20,000	180	47-3/32	1-1/2 x 5 x 10			2-1/4	1,669	TBB-20-180
20,000	240	44-3/32	1-1/2 x 5 x 10			2-1/4	2,128	TBB-20-240
40,000	120	61-1/16	1-1/2 x 6 x 18			3-5/8	1,346	TBB-40-120
40,000	180	61-1/16	1-1/2 x 6 x 18			3-5/8	2,171	TBB-40-180
40,000	240	61-1/16	1-1/2 x 6 x 18			3-5/8	3,050	TBB-40-240
60,000	120	63-3/8	1-3/4 x 6 x 18			3-3/4	1,869	TBB-60-120
60,000	180	63-3/8	1-3/4 x 6 x 18			3-3/4	2,822	TBB-60-180
60,000	240	63-3/8	1-3/4 x 6 x 18			3-3/4	3,828	TBB-60-240

**Model 26 - Load Leveler Lifting Beam**

- Ideal for infinite adjustment of bail.
- Adjustable spread options available.
- Swivel hooks with hook latches standard.
- Motorized adjustable bail available.
- Wide range of sizes and capacities available.
- Designed and manufactured to ASME B30.20.

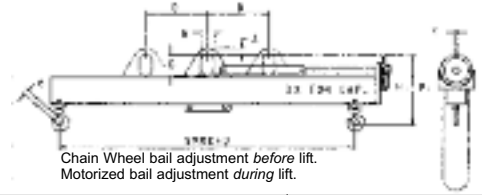

Capacity (tons)	Catalog # Head Room (in) Wt. (lbs)	Spread (in Feet)										Other Dimensions (in)	
		4'	6'	8'	10'	12'	14'	16'	18'	20'	24'	A=1-1/2 B=3 C=5	T=5/8 0=1
2	CAT.	26-2-4	26-2-6	26-2-8	26-2-10	26-2-12	26-2-14	26-2-16	26-2-18	26-2-20	26-2-24	A=2	T=1
2	H.R.(in)	15-1/8	15-1/8	16-1/8	17-1/8	18-1/8	18-1/8	18-1/8	19-1/8	20-1/8	20-1/8	B=4	0=1-11/32
2	WT.(lbs)	135	177	248	329	377	481	538	680	750	1,265	C=7	
5	CAT.	26-5-4	26-5-6	26-5-8	26-5-10	26-5-12	26-5-14	26-5-16	26-5-18	26-5-20	26-5-24	A=2	T=1
5	H.R.(in)	20-1/2	21-1/2	22-1/2	23-1/2	25-1/2	25-1/2	25-1/2	28-1/2	28-1/2	28-1/2	B=4	0=1-11/32
5	WT.(lbs)	166	270	382	475	681	777	869	1,455	1,603	2,345	C=7	
10	CAT.	26-10-4	26-10-6	26-10-8	26-10-10	26-10-12	26-10-14	26-10-16	26-10-18	26-10-20	26-10-24	A=2	T=1-1/4
10	H.R.(in)	25-3/4	28-3/4	28-3/4	31-3/4	31-3/4	31-3/4	31-3/4	34-3/4	34-3/4	34-3/4	B=4	0=2-1/16
10	WT.(lbs)	257	493	602	849	1,094	1,243	1,388	1,875	2,056	2,560	C=7	
15	CAT.	26-15-4	26-15-6	26-15-8	26-15-10	26-15-12	26-15-14	26-15-16				A=2-1/2	T=-1-1/2
15	H.R.(in)	30-1/2	33-1/2	33-1/2	33-1/2	36-1/2	36-1/2	36-1/2				B=5	0=2-1/16
15	WT.(lbs)	376	565	622	972	1,319	1,418	1,513				C=9	
20	CAT.	26-20-4	26-20-6	26-20-8	26-20-10	26-20-12						A=2-1/2	T=1-1/2
20	H.R.(in)	34	37	37	37	37						B=5	0=2-1/4
20	WT.(lbs)	445	798	900	997	1,353						C=9	
Bail Adjustment (in)		D=8	D=12	D=16	D=20	D=24	D=28	D=32	D=36	D=40	D=48		

**HOW TO SPECIFY BEAMS**

Some beams are stocked for quick delivery but most are made to order. We stock many of the component parts such as hooks, shackles, hoist hook attachment loops and removable "Faspins." However, structural components are cut to length as required. Therefore, for lowest initial cost and operating savings, specify a lifter that meets your particular requirements exactly as to capacity, length, hook adjustment, etc. Deliveries for customer specified beams are the same as for non-stock catalog items.

For odd shaped loads, please provide the following:

- 1 Max. weight \_\_\_\_\_ lbs
- 2 Shape of load. Is the load a box, drum or other cylinder, assembly of machines mounted

on a rectangular sub-base, bundle, or irregularly-shaped object? Submit a sketch for complex loads.

- 3 Where is the center of gravity?
  - a Horizontal distance from one end \_\_\_\_\_"
  - b Horizontal distance from one side \_\_\_\_\_"
  - c Vertical distance from bottom \_\_\_\_\_"

(If there are several different loads, give dimensions a, b and c for each.)

- 4 Give locations and dimensions of holes, lugs or openings to be used for lifting. Location of these with respect to outline dimensions and center of gravity location is important.
- 5 Are there parts of the object that will be

damaged by contact with slings?

- 6 Give size and location of spacing materials under the load.
- 7 Is it necessary to tilt or change the angle of the load before setting down?

**Hook Dimensions**

1. \_\_\_\_\_

2. \_\_\_\_\_

3. \_\_\_\_\_

4. \_\_\_\_\_

5. \_\_\_\_\_

6. \_\_\_\_\_

7. \_\_\_\_\_

8. \_\_\_\_\_

Capacity \_\_\_\_\_ Tons

## Lifting Beams

### Model 22 - Heavy Duty Twin Basket Sling Lifting Beam

- Designed to be used with slings in a basket hitch.
- Specially designed hooks with hook latches minimize potential sling damage.
- Two sets of fixed hooks are standard in all lengths over 4'.
- The inner set of hooks are 1/2 the overall spread.
- Extra spreads available upon request.
- Designed and manufactured to ASME B30.20.

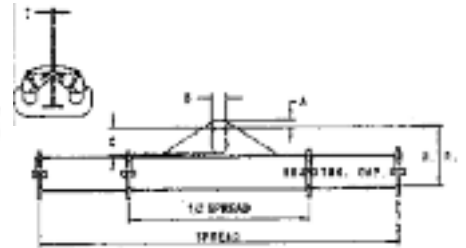

Capacity (tons)	Catalog# Head Room (in) Wt. (lbs)	Spread (in Feet)												Other Dimensions (in)	
		3'	4'	6'	8'	10'	12'	14'	16'	18'	20'	24'	30'		
1/2	CAT.	22-1/2-3	22-1/2-4	22-1/2-6	22-1/2-8	22-1/2-10	22-1/2-12	22-1/2-14	22-1/2-16	22-1/2-18	22-1/2-20	22-1/2-24	22-1/2-30	A=1-1/2	T=5/8
1/2	H.R. (in)	8-1/2	8-1/2	8-1/2	8-1/2	9-1/2	9-1/2	10-1/2	10-1/2	11-1/2	11-1/2	12-1/2	13-1/2	B=3	O=2
1/2	WT. (lbs)	50	65	110	150	200	220	298	331	424	463	627	855	C=5	
1	CAT.	22-1/3	22-1-4	22-1-6	22-1-8	22-1-10	22-1-12	22-1-14	22-1-16	22-1-18	22-1-20	22-1-24	22-1-30	A=1-1/2	T=5/8
1	H.R. (in)	8-1/2	8-1/2	9-1/2	9-1/2	10-1/2	11-1/2	11-1/2	12-1/2	13-1/2	13-1/2	15-1/2	15-1/2	B=3	O=2
1	WT. (lbs)	50	65	145	210	230	290	338	390	539	588	907	1,150	C=5	
2	CAT.	22-2-3	22-2-4	22-2-6	22-2-8	22-2-10	22-2-12	22-2-14	22-2-16	22-2-18	22-2-20	22-2-24	22-2-30	A=1-1/2	T=5/8
2	H.R. (in)	9-1/2	10-1/2	10 1/2	11-1/2	12-1/2	12-1/2	13-1/2	14-1/2	15-1/2	15-1/2	17-1/2	20-1/2	B=3	O=3
2	WT. (lbs)	70	90	160	225	300	375	447	515	725	815	1,221	2,272	C=5	
5	CAT.	22-5-3	22-5-4	22-5-6	22-5-8	22-5-10	22-5-12	22-5-14	22-5-16	22-5-18	22-5-20	22-5-24	22-5-30	A=2	T=1
5	H.R. (in)	13-1/2	14-1/2	15-1/2	16-1/2	16-1/2	17-1/2	19-1/2	19-1/2	22-1/2	22-1/2	22-1/2	25-1/2	B=4	O=3
5	WT. (lbs)	90	160	275	350	450	500	722	835	1,398	1,556	2,144	3,119	C=7	
7-1/2	CAT.	22-7 1/2-3	22-7 1/2-4	22-7 1/2-6	22-7 1/2-8	22-7 1/2-10	22-7 1/2-12	22-7 1/2-14	22-7 1/2-16	22-7 1/2-18	22-7 1/2-20	22-7 1/2-24	22-7 1/2-30	A=2	T=1-1/4
7-1/2	H.R. (in)	14-1/2	15-1/2	16-1/2	17-1/2	19-1/2	19-1/2	22-1/2	22-1/2	22-1/2	22-1/2	25-1/2	25-1/2	B=4	O=3-1/2
7-1/2	WT. (lbs)	155	180	330	410	500	700	1,162	1,300	1,468	1,606	2,354	2,877	C=7	
10	CAT.	22-10-3	22-10-4	22-10-6	22-10-8	22-10-10	22-10-12	22-10-14	22-10-16	22-10-18	22-10-20	22-10-24	22-10-30	A=2	T=1-1/4
10	H.R. (in)	15-1/2	16-1/2	17-1/2	19-1/2	19-1/2	22-1/2	22-1/2	25-1/2	25-1/2	25-1/2	25-1/2	25-1/2	B=4	O=3-1/2
10	WT. (lbs)	150	200	320	500	590	700	1,147	1,299	1,741	1,943	2,335	2,962	C=7	
15	CAT.	22-15-3	22-15-4	22-15-6	22-15-8	22-15-10	22-15-12	22-15-14	22-15-16	22-15-18	22-15-20	22-15-24		A=2-1/2	T=1-1/2
15	H.R. (in)	18-1/2	19-1/2	21-1/2	21-1/2	24-1/2	24-1/2	24-1/2	27-1/2	27-1/2	27-1/2	27-1/2		B=5	O=4
15	WT. (lbs)	397	471	553	12,40	1,256	1,980	2,065	2,108	2,391	2,584	4,045		C=9	
20	CAT.	22-20-3	22-20-4	22-20-6	22-20-8	22-20-10	22-20-12	22-20-14	22-20-16	22-20-18	22-20-20	22-20-24		A=2-1/2	T=1-1/2
20	H.R. (in)	19-1/2	21-1/2	21-1/2	24-1/2	24-1/2	24-1/2	27-1/2	27-1/2	27-1/2	27-1/2			B=5	O=4
20	WT. (lbs)	253	328	910	1,240	1,581	1,740	1,494	1,898	2,050	2,247			C=8	

13  
Below the Hook Lifting

## Spreader Beams

### Model 30 - Fixed Spreader Beams

- Ideal where headroom is not limited.
- Adds stability to lift.
- Available with chain, wire rope or Adjust-A-Leg® top rigging options.
- Available with off center load adjustment.
- Wide range of additional sizes and capacities available.
- Designed and manufactured to ASME B30.20.

NOTE: Weight = Beam & hooks only - (no top rigging).



Specify Top Rigging

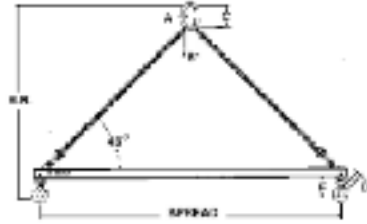

Capacity (tons)	Catalog # Head Room (in) Wt. (lbs)	Spread in Feet								Other Dimensions (in)	
		4'	6'	8'	10'	12'	16'	20'	24'		
2	CAT.	30-2-4	30-2-6	30-2-8	30-2-10	30-2-12	30-2-16	30-2-20	30-2-24	A=1/2	F=4-1/2
2	H.R. (in)	33	45	57	70	82	106	132	156	B=2-1/2	O=31-32
2	WT. (lbs)	45	60	82	95	115	225	408	445	C=5	
5	CAT.	30-5-4	30-5-6	30-5-8	30-5-10	30-5-12	30-5-16	30-5-20	30-5-24	A=1	F=6
5	H.R. (in)	37	49	61	73	85	109	133	158	B=3-1/2	O=1-11/32
5	WT. (lbs)	62	78	100	117	168	305	435	661	C=7	
10	CAT.	30-10-4	30-10-6	30-10-8	30-10-10	30-10-12	30-10-16	30-10-20	30-10-24	A=1-1/4	F=8-1/8
10	H.R. (in)	41	53	65	77	89	113	137	163	B=4-3/8	O=1-11/16
10	WT. (lbs)	100	122	156	180	240	380	532	915	C=8-3/4	
15	CAT.	30-15-4	30-15-6	30-15-8	30-15-10	30-15-12	30-15-16	30-15-20	30-15-24	A=1-1/2	F=9-1/4
15	H.R. (in)	43	55	67	80	92	116	141	167	B=5-1/4	O=2-1/16
15	WT. (lbs)	126	155	185	242	270	415	665	953	C=10-1/2	
20	CAT.	30-20-4	30-20-6	30-20-8	30-20-10	30-20-12	30-20-16	30-20-20	30-20-24	A=1-3/4	F=9-3/4
20	H.R. (in)	45	57	69	82	94	118	143	170	B=6	O=2-1/4
20	WT. (lbs)	170	200	233	315	350	460	775	1,341	C=12	
30	CAT.		30-30-6	30-30-8	30-30-10	30-30-12	30-30-16	30-30-20		A=2	F=13
30	H.R. (in)		62	74	87	100	125	150		B=7	O=3
30	WT. (lbs)		285	402	440	530	888	1,390		C=14	
40	CAT.		30-40-6	30-40-8	30-40-10	30-40-12	30-40-16			A=2	F=13
40	H.R. (in)		64	76	89	102	127			B=7	O=3
40	WT. (lbs)		563	695	781	1,058	1,364			C=14	

- Top Rigging Options**
- Option C** - Chain top rigging from beam to crane hook.
  - Option W** - Wire rope top rigging from beam to crane hook.
  - Option A** - Adjust-A-Leg® sling top rigging for off center load adjustment (not included in Quickship Program).

**Below the Hook Lifting**

**Spreader Beams**

**Model 32 - Adjustable Spreader Beams**

- Ideal where headroom is not limited.
  - Adds stability to lift.
  - Telescopic adjustable spread standard.
  - Available with chain, wire rope or Adjust-A-Leg® top rigging options.
  - Available with off center load adjustment.
  - Wide range of additional sizes and capacities available.
  - Designed and manufactured to ASME B30.20.
- NOTE: Weight = Beam & hooks only - (no top rigging).

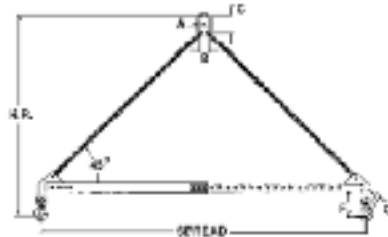

**Option HC**  
Hand crank for easier adjustment capabilities (\*not available on 12-20 ft. models)

Head Capacity (tons)	Catalog# Room (in) Wt. (lbs)	Spread in Feet (Adjustments in 1" Increments)												Other Dimensions (in)	
		Min.	Max.	Min.	Max.	Min.	Max.	Min.	Max.	Min.	Max.	Min.	Max.	A=1/2 B=2-1/2 C=5	F=7-1/2 O=1
2	CAT. H.R.(in) WT.(lbs)	32-2-4/6	4'-0 57	6'-0 43	32-2-6/10	6'-0 89	10'-0 67	32-2-8/14	8'-0 121	14'-0 91	32-2-12-20*	12'-0 165	20'-0 127	A=1/2 B=2-1/2 C=5	F=7-1/2 O=1
5	CAT. H.R.(in) WT.(lbs)	32-5-4/6	4'-0 59	6'-0 45	32-5-6/10	6'-0 91	10'-0 69	32-5-8/14	8'-0 123	14'-0 93	32-5-12-20*	12'-0 167	20'-0 129	A=1 B=3-1/2 C=7	F=9 O=1-11/32
10	CAT. H.R.(in) WT.(lbs)	32-10-4/6	4'-0 61	6'-0 47	32-10-6/10	6'-0 93	10'-0 71	32-10-8/14	8'-0 125	14'-0 95	32-10-12-20*	12'-0 169	20'-0 131	A=1-1/4 B=4-3/8 C=8-3/4	F=11-1/2 O=1-11/16
15	CAT. H.R.(in) WT.(lbs)	32-15-4/6	4'-0 63	6'-0 49	32-15-6/10	6'-0 95	10'-0 73	32-15-8/14	8'-0 127	14'-0 96	32-15-12-20*	12'-0 171	20'-0 133	A=1-1/4 B=5-1/4 C=10-1/2	F=13 O=2-1/16

**Top Rigging Options:** **Option C** - Chain top rigging from beam to crane hook. **Option W** - Wire rope top rigging from beam to crane hook.  
**Option A** - Adjust-A-Leg® sling top rigging for off center load adjustment (not included in Quickship Program).

**Model 76 Series - Fiberglass Spreader Beams**

Used for applications that require a non-conductive beam such as lifting industrial fork lift truck batteries.

Caldwell Battery Lifting Beams provide a convenience in battery handling. The beams are non-conductive, light weight and very easy to handle, making them ideal for moving batteries to and from forklift trucks or from one storage location to another.

- Lightweight only weighs 14-18 lbs. - 70% lighter than other beams.
- Models are available for handling batteries of equal length or of different lengths.
- Heavy duty 4800 lb. and 7000 lb. capacities. Non-conductive fiberglass beam construction. Acid-resistant, coated polyester straps and hooks.

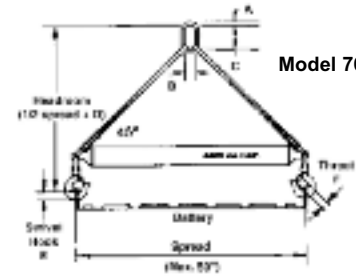

**Model 76**

**Model 76 - Fixed (Batteries of Equal Length)**

Model No.	Rated Capacity (lbs.)	Std. Spread (in)	Dimensions (in)						Wt. (lbs)
			A	B	C	D	E	F	
76-2.4	4,800	36	5/8	3	6	11	27/32	21/32	14
76-3.5	7,000	36	3/4	2-3/4	5-1/2	12	1	1	16

For battery beams other than standard spread. Measure distance between lifting points. Specify Model 76 with beam spread (in even inches) equal to length measured.

**Model 76E - Adjustable (Batteries of Different Length)**

Model No.	Rated Capacity (lbs.)	Std. Spread (in)	Dimensions (in)						Wt. (lbs)
			A	B	C	D	E	F	
76E-2.4	4,800	36	5/8	3	6	21	1	1	16
76E-3.5	7,000	36	3/4	2-3/4	5-1/2	22-1/2	1-1/8	1-1/8	18

For battery beams other than standard spread. Take average of shortest and longest batteries, and specify Model 76E with beam spread (in even inches) equal to average lengths. Battery length must be within 12 inches, shortest to longest.

NOTE: For Model 76E lifting beams, battery length cannot differ more than 6 inches from length of beam spread.

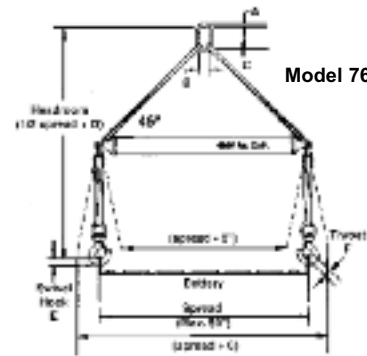

**Model 76E**

**NEW SAFETY STANDARD AVAILABLE**

Hazards in using Below Hook Lifters cannot be overcome solely by mechanical means. It is absolutely necessary that the lifter operator himself exercise intelligence, care, common sense and experience to anticipate motions that may occur as the load is lifted. It is essential that the lifter operator be trained in the safe

operation of lifters and be alert and competent. We strongly recommend that users obtain a copy of the new ANSI Safety/Standard Below-the-Hook Lifting Devices. The standard covers marking, inspection, testing, maintenance and safe operation of all types of below-the-hook lifters. It can be ordered for \$40.00 plus ship-

ping and includes 5 years of addendi service. It is \$32.00 for ASME members who furnish their name and ASME number. The standard can be ordered from:  
ASME Order Dept: 22 Law Dr., Fairfield, NJ 07007-2300 Phone: 1-201-882-1167 or 1-800-THE-ASME

## Custom Lifters

### Custom Lifting Beams

#### Model FHB - Fixed Hook Lifting Beam

An ideal solution for lifting loads where headroom is critical

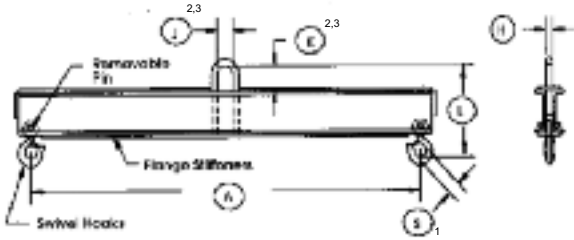

#### Model AHB - Adjustable Hook Lifting Beam

An ideal solution for lifting off center loads or varying load lengths where headroom is critical

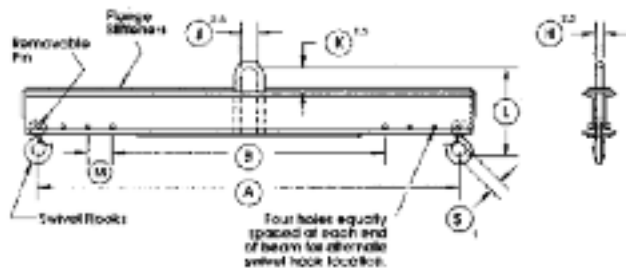

#### Model TBB - Twin Bail Lifting Beam

An ideal solution for utilizing two lifting hoists to increase lifting capacity

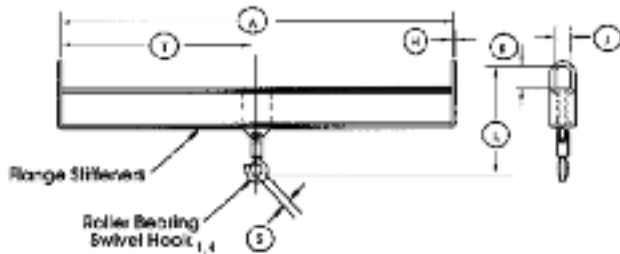

Model FHB  Model AHB  Model TBB

Capacity \_\_\_\_\_ lbs.

- A \_\_\_\_\_ Max. Distance Between Hooks
- B \_\_\_\_\_ Min. Distance Between Hooks
- \*H \_\_\_\_\_ Bail Thk.
- \*J \_\_\_\_\_ Bail Width
- \*K \_\_\_\_\_ Bail Height
- \*L \_\_\_\_\_ Total Height
- M \_\_\_\_\_ Hook Space
- \*S \_\_\_\_\_ Max. Stock Diameter
- \*T \_\_\_\_\_ Distance to Hook

\* Optional Data

- 1 Max. stock diameter refers to the size of material that will fit into the swivel hook opening.
- 2 All loads must be centered under the lifting bail.
- 3 Please verify that the lifting bail size will suit the crane hook.
- 4 Standard swivel Hook Optional.

Additional Information: \_\_\_\_\_

### Custom Three Point Lifter

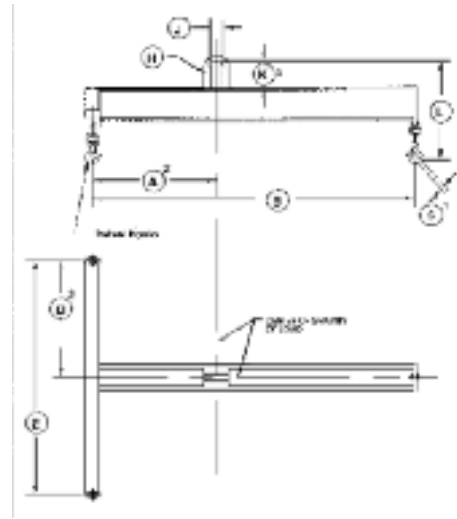

#### Model TPL - 3-Point Lifting Frame

An ideal solution to handle large loads requiring multiple pick points. Lifting bail can be designed to handle off center loads.

### Custom Four Point Lifter

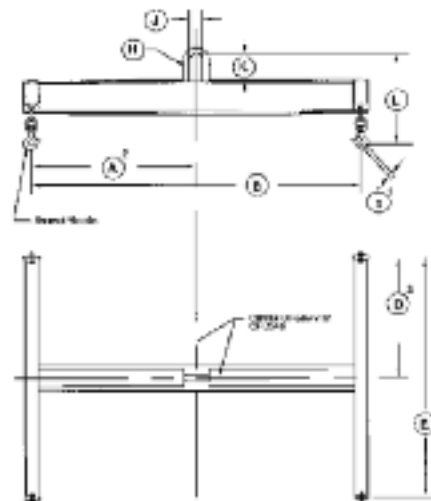

#### Model FPL - 4-Point Lifting Frame

An ideal solution to handle large loads requiring multiple pick points. Lifting bail can be designed to handle off center loads.

Model TPL  Model FPL

Capacity \_\_\_\_\_ lbs.

- A \_\_\_\_\_ Distance to Bail
- B \_\_\_\_\_ Overall Length
- D \_\_\_\_\_ Distance to Bail
- E \_\_\_\_\_ Overall Length
- \*H \_\_\_\_\_ Bail Thickness
- \*J \_\_\_\_\_ Bail Width
- \*K \_\_\_\_\_ Bail Height
- \*L \_\_\_\_\_ Total Height
- \*S \_\_\_\_\_ Maximum Stock Dia.

\* Optional Data

- 1 Max. stock diameter refers to the size of material that will fit into the swivel hook opening.
- 2 All loads must be centered under the lifting bail.
- 3 Please verify that the lifting bail size will suit the crane hook.

Additional Information: \_\_\_\_\_

**Below the Hook Lifting**

**C-Hook Lifters**

**Model TLC - Tubular Low Cost C-Hooks**

The Tubular Low Cost C-hook has a longer upper arm and a smaller counterweight to produce a lighter weight lifter.

The tubular design is a cost saving option for capacities not exceeding 20,000 lbs..

External weld reinforcing plates strengthens both the weld and tube at critical stress areas.

All lifters are proof tested exceeding ANSI/ASME B30.20 standards and test certificate issued. Painted safety yellow and clearly marked on both sides with rated capacity to conform to OSHA standards.

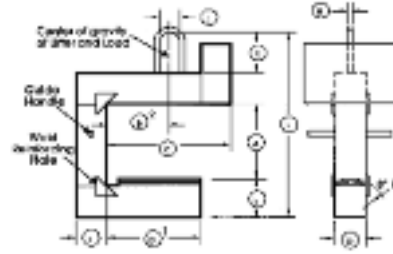

Capacity <sup>4</sup> (lbs)	Coil Width		Vertical Clear A (in)	Dist. to Center of Gravity B (in)	Upper Arm Length C (in)	Lift Arm Length D (in)	Lift Arm Depth E (in)	Vertical Post Depth F (in)	Lift Arm Width G (in)	Bail Size <sup>3</sup> H J K (in)	Total Height L (in)	Approx. Lifter Wt. (lbs)	Model No.
	Max. (in)	Min. (in)											
1,000	12	8	12	6	12	10	3-1/2	3	3	3/4 x 2 x 4	22-1/2	78	TLC-1-12-8-12
1,000	24	16	12	12	23	20	3-1/2	3	3	3/4 x 2 x 4	22-1/2	74	TLC-1-24-16-12
1,000	36	22	12	18	33	29	3-1/2	3	3	3/4 x 2 x 4	22-1/2	93	TLC-1-36-22-12
1,000	48	30	12	24	43	39	3-1/2	3	3	3/4 x 2 x 4	22-1/2	111	TLC-1-48-30-12
2,000	24	16	16	12	23	20	4-3/4	4	4	3/4 x 2 x 4	28-3/4	118	TLC-2-24-16-16
2,000	36	22	16	18	33	29	4-3/4	4	4	3/4 x 2 x 4	28-3/4	145	TLC-2-36-22-16
2,000	48	30	16	24	43	39	4-3/4	6	4	3/4 x 2 x 4	28-3/4	193	TLC-2-48-30-16
4,000	24	16	20	12	23	20	6-5/8	6	4	1 x 2 x 4	36-5/8	183	TLC-4-24-16-20
4,000	36	22	20	18	33	29	6-5/8	6	4	1 x 2 x 4	36-5/8	213	TLC-4-36-22-20
4,000	48	30	20	24	44	39	6-7/8	6	6	1 x 2 x 4	36-7/8	299	TLC-4-48-30-20
6,000	36	22	24	18	34	29	6-7/8	8	6	1-1/4 x 4 x 6	42-7/8	320	TLC-6-36-22-24
6,000	48	30	24	24	44	39	8-7/8	8	6	1-1/4 x 4 x 6	46-7/8	395	TLC-6-48-30-24
8,000	36	22	26	18	34	29	9-3/8	8	8	1-1/2 x 4 x 8	51-3/8	441	TLC-8-36-22-26
8,000	48	30	26	24	44	39	9-3/8	8	8	1-1/2 x 4 x 8	51-3/8	604	TLC-8-48-30-26
8,000	60	36	26	30	54	48	9-3/8	8	8	1-1/2 x 4 x 8	51-3/8	670	TLC-8-60-36-26
10,000	36	22	26	18	34	29	9-3/8	8	8	1-1/2 x 4 x 10	53-3/8	450	TLC-10-36-22-26
10,000	48	30	26	24	44	39	9-3/8	10	8	1-1/2 x 4 x 10	53-3/8	684	TLC-10-48-30-26
10,000	60	36	26	30	54	48	11-3/8	10	8	1-1/2 x 4 x 10	57-3/8	814	TLC-10-60-36-26
15,000	36	22	28	18	34	29	9-3/8	10	8	1-3/4 x 5 x 10	55-3/8	637	TLC-15-36-22-28
15,000	48	30	28	24	44	39	12-1/8	10	10	1-3/4 x 5 x 10	60-1/8	879	TLC-15-48-30-28
15,000	60	36	28	30	54	48	12-1/8	10	10	1-3/4 x 5 x 10	60-1/8	1340	TLC-15-60-36-28
20,000	36	22	30	18	34	29	12-3/8	10	10	1-3/4 x 5 x 10	62-3/8	862	TLC-20-36-22-30
20,000	48	30	30	24	44	39	12-3/8	10	10	1-3/4 x 5 x 10	62-3/8	1284	TLC-20-48-30-30
20,000	60	36	30	30	56	48	12-3/8	14	10	1-3/4 x 5 x 10	62-3/8	1580	TLC-20-60-36-30

- 1 Lifting arm length allows minimum coil width to be handled w/o protrusion of lift arm past edge of coil.
- 2 All coils must be centered under the lifting bail.
- 3 Please verify that the lifting bail size will suit crane hook.
- 4 Other capacities and lengths available upon request.

**Model TCS - Tubular Close Stacking C-Hooks**

The Tubular Close Stacking C-hook has a shorter upper arm for handling various coil widths flush against a vertical surface.

The tubular design is a cost saving option for capacities not exceeding 20,000 lbs.

External weld reinforcing plates strengthens both the weld and tube at critical stress areas.

All lifters are proof tested exceeding ANSI/ASME B30.20 standards and test certificate issued. Painted safety yellow and clearly marked on both sides with rated capacity to conform to OSHA standards.

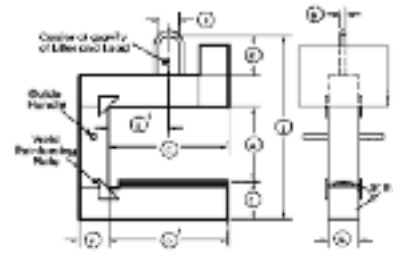

Capacity <sup>4</sup> (lbs)	Coil Width		Vertical Clear A (in)	Dist. to Center of Gravity B (in)	Upper Arm Length C (in)	Lift Arm Length D (in)	Lift Arm Depth E (in)	Vertical Post Depth F (in)	Lift Arm Width G (in)	Bail Size <sup>3</sup> H J K (in)	Total Height L (in)	Approx. Lifter Wt. (lbs)	Model No.
	Min. (in)	Max. (in)											
1,000	12	8	12	6	10	10	3-1/2	3	3	3/4 x 2 x 4	22-1/2	79	TCS-1-12-8-12
1,000	24	16	12	12	20	20	3-1/2	3	3	3/4 x 2 x 4	22-1/2	88	TCS-1-24-16-12
1,000	36	22	12	18	29	29	3-1/2	3	3	3/4 x 2 x 4	22-1/2	109	TCS-1-36-22-12
1,000	48	30	12	24	39	39	3-1/2	3	3	3/4 x 2 x 4	22-1/2	123	TCS-1-48-30-12
2,000	24	16	16	12	20	20	4-3/4	4	4	3/4 x 2 x 4	28-3/4	142	TCS-2-24-16-16
2,000	36	22	16	18	29	29	4-3/4	4	4	3/4 x 2 x 4	28-3/4	170	TCS-2-36-22-16
2,000	48	30	16	24	39	39	4-3/4	6	4	3/4 x 2 x 4	28-3/4	218	TCS-2-48-30-16
4,000	24	16	20	12	20	20	6-5/8	6	4	1 x 2 x 4	36-5/8	228	TCS-4-24-16-20
4,000	36	22	20	18	29	29	6-5/8	6	4	1 x 2 x 4	36-5/8	258	TCS-4-36-22-20
4,000	48	30	20	24	39	39	6-7/8	6	6	1 x 2 x 4	36-7/8	350	TCS-4-48-30-20
6,000	36	22	24	18	29	29	6-7/8	8	6	1-1/4 x 4 x 6	42-7/8	413	TCS-6-36-22-24
6,000	48	30	24	24	39	39	8-7/8	8	6	1-1/4 x 4 x 6	46-7/8	465	TCS-6-48-30-24
8,000	36	22	26	18	29	29	9-3/8	8	8	1-1/2 x 4 x 8	51-3/8	566	TCS-8-36-22-26
8,000	48	30	26	24	39	39	9-3/8	8	8	1-1/2 x 4 x 8	51-3/8	719	TCS-8-48-30-26
8,000	60	36	26	30	48	48	9-3/8	8	8	1-1/2 x 4 x 8	51-3/8	789	TCS-8-60-36-26
10,000	36	22	26	18	29	29	9-3/8	8	8	1-1/2 x 4 x 10	53-3/8	590	TCS-10-36-22-26
10,000	48	30	26	24	39	39	9-3/8	10	8	1-1/2 x 4 x 10	53-3/8	839	TCS-10-48-30-26
10,000	60	36	26	30	48	48	11-3/8	10	8	1-1/2 x 4 x 10	57-3/8	979	TCS-10-60-36-26
15,000	36	22	28	18	29	29	9-3/8	10	8	1-3/4 x 5 x 10	55-3/8	845	TCS-15-36-22-28
15,000	48	30	28	24	39	39	12-1/8	10	10	1-3/4 x 5 x 10	60-1/8	1,075	TCS-15-48-30-28
15,000	60	36	28	30	48	48	12-1/8	10	10	1-3/4 x 5 x 10	60-1/8	1,617	TCS-15-60-36-28
20,000	36	22	30	18	29	29	12-3/8	10	10	1-3/4 x 5 x 10	62-3/8	1,199	TCS-20-36-22-30
20,000	48	30	30	24	39	39	12-3/8	10	10	1-3/4 x 5 x 10	62-3/8	1,575	TCS-20-48-30-30
20,000	60	36	30	30	48	48	12-3/8	14	10	1-3/4 x 5 x 10	62-3/8	2,072	TCS-20-60-36-30

- 1 Lifting arm length allows minimum coil width to be handled w/o protrusion of lift arm past edge of coil.
- 2 All coils must be centered under the lifting bail.
- 3 Please verify that the lifting bail size will suit crane hook.
- 4 Other capacities and lengths available upon request.

13 Below the Hook Lifting



# C-Hook Lifters

## Model TCF - Tubular Close Stacking C-Hooks with Flame Cut Lift Arm

The Tubular Close Stacking C-hook has a shorter upper arm for handling various coil widths flush against a vertical surface and a flame cut high strength alloy steel lift arm allowing for direct loading and unloading.

External weld reinforcing plates strengthens both the weld and tube at critical stress areas.

All lifters are proof tested exceeding ANSI/ASME B30.20 standards and test certificate issued. Painted safety yellow and clearly marked on both sides with rated capacity to conform to OSHA standards.

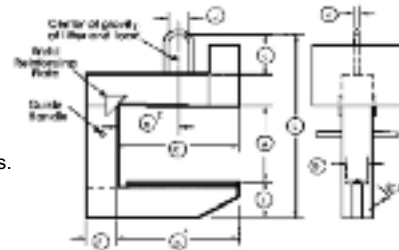

Capacity <sup>4</sup> (lbs)	Coil Width		Vertical Clear A (in)	Dist. to Center of Gravity B (in)	Upper Arm Length C (in)	Lift Arm Length D (in)	Lift Arm Depth E (in)	Vertical Post Depth F (in)	Lift Arm Width G (in)	Bail Size <sup>3</sup> H J K (in)	Total Height L (in)	Approx. Lifter Wt. (lbs)	Model No.
	Max. (in)	Min. (in)											
1,000	12	8	12	6	10	10	2-5/8	3	3	3/4 x 2 x 4	21-5/8	86	TCF-1-12-8-12
1,000	24	16	12	12	20	20	3-1/8	3	3	3/4 x 2 x 4	22-1/8	95	TCF-1-24-16-12
1,000	36	22	12	18	29	29	3-5/8	3	3	3/4 x 2 x 4	22-3/8	119	TCF-1-36-22-12
1,000	48	30	12	24	39	39	4-1/8	3	3	3/4 x 2 x 4	23-1/8	133	TCF-1-48-30-12
2,000	24	16	16	12	20	20	4-1/8	4	3	3/4 x 2 x 4	28-1/8	154	TCF-2-24-16-16
2,000	36	22	16	18	29	29	3-1/2	4	3	3/4 x 2 x 4	27-1/2	184	TCF-2-36-22-16
2,000	48	30	16	24	39	39	4-5/8	6	3	3/4 x 2 x 4	28-5/8	238	TCF-2-48-30-16
4,000	24	16	20	12	20	20	4-5/8	6	4	1 x 2 x 4	34-5/8	247	TCF-4-24-16-20
4,000	36	22	20	18	29	29	5	6	4	1 x 2 x 4	35	280	TCF-4-36-22-20
4,000	48	30	20	24	39	39	5-5/8	6	4	1 x 2 x 4	35-5/8	380	TCF-4-48-30-20
6,000	36	22	24	18	29	29	5-7/8	8	4	1-1/4 x 4 x 6	41-7/8	448	TCF-6-36-22-24
6,000	48	30	24	24	39	39	4-3/4	8	4	1-1/4 x 4 x 6	42-3/4	504	TCF-6-48-30-24
8,000	36	22	26	18	29	29	4-3/4	8	4	1-1/2 x 4 x 8	46-3/4	614	TCF-8-36-22-26
8,000	48	30	26	24	39	39	5-1/2	8	4	1-1/2 x 4 x 8	47-1/2	780	TCF-8-48-30-26
8,000	60	36	26	30	48	48	6	8	4	1-1/2 x 4 x 8	48	856	TCF-8-60-36-26
10,000	36	22	26	18	29	29	5-3/8	8	4	1-1/2 x 4 x 10	49-3/8	640	TCF-10-36-22-26
10,000	48	30	26	24	39	39	6	10	4	1-1/2 x 4 x 10	50	910	TCF-10-48-30-26
10,000	60	36	26	30	48	48	6-5/8	10	4	1-1/2 x 4 x 10	52-5/8	1,062	TCF-10-60-36-26
15,000	36	22	28	18	29	29	6	10	4	1-3/4 x 5 x 10	52	917	TCF-15-36-22-28
15,000	48	30	28	24	39	39	6-3/4	10	4	1-3/4 x 5 x 10	54-3/4	1,166	TCF-15-48-30-28
15,000	60	36	28	30	48	48	7-1/2	10	4	1-3/4 x 5 x 10	55-1/2	1,755	TCF-15-60-36-28
20,000	36	22	30	18	29	29	6-3/4	10	4	1-3/4 x 5 x 10	56-3/4	1,301	TCF-20-36-22-30
20,000	48	30	30	24	39	39	7-3/4	10	4	1-3/4 x 5 x 10	57-3/4	1,705	TCF-20-48-30-30
20,000	60	36	30	30	48	48	8-1/2	14	4	1-3/4 x 5 x 10	58-1/2	2,247	TCF-20-60-36-30

- Lifting arm length allows minimum coil width to be handled w/o protrusion of lift arm past edge of coil.
- All coils must be centered under the lifting bail.
- Please verify that the lifting bail size will suit crane hook.
- Other capacities and lengths available upon request.

13  
Below the Hook Lifting

## Model LCC - Low Cost C-Hooks, High Strength Steel

The Low Cost C-hook has a longer upper arm and a smaller counterweight to produce a lighter weight lifter.

Integral lifting bail saves headroom and minimizes inspection normally associated with welded lifting balls.

High strength alloy steel reduces the physical size of the lift arm allowing movement into confined areas for direct crane loading and unloading.

All lifters are proof tested exceeding ANSI/ASME B30.20 standards and test certificate issued. Painted safety yellow and clearly marked on both sides with rated capacity to conform to OSHA standards.

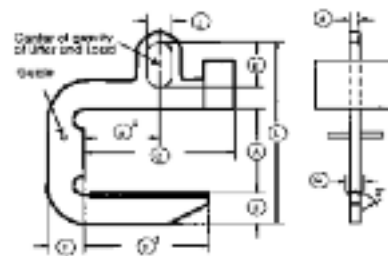

Capacity <sup>4</sup> (lbs)	Coil Width		Vertical Clear A (in)	Dist. to Center of Gravity B (in)	Upper Arm Length C (in)	Lift Arm Length D (in)	Lift Arm Depth E (in)	Vertical Post Depth F (in)	Lift Arm Width G (in)	Bail Size <sup>3</sup> H J K (in)	Total Height L (in)	Approx. Lifter Wt. (lbs)	Model No.
	Max. (in)	Min. (in)											
1,000	36	24	16	18	35	30	5-1/4	8	4	1-1/2 x 4 x 10	34-5/8	360	LCC-10-36-24-16
1,000	48	30	24	24	44	39	6-1/8	8-3/4	4	1-1/2 x 4 x 10	42-5/8	403	LCC-10-36-24-24
1,000	60	36	24	30	56	48	6-7/8	9-1/2	4	1-1/2 x 4 x 10	35-1/2	504	LCC-10-48-30-16
			16	24							43-1/2	552	LCC-10-48-30-24
			24	30							35-7/8	632	LCC-10-60-36-16
			30	36							43-7/8	689	LCC-10-60-36-24
2,000	36	24	24	18	35	30	7-1/4	9-5/8	4	1-3/4 x 4 x 10	44-1/4	617	LCC-20-36-24-24
2,000	48	30	24	24	47	39	7-7/8	9-7/8	4	1-3/4 x 4 x 10	50-1/4	737	LCC-20-36-24-30
2,000	60	36	24	30	56	48	8-3/4	11-3/4	4	1-3/4 x 4 x 10	44-7/8	834	LCC-20-48-30-24
2,000	72	42	24	36	65	57	10-1/8	13-5/8	4	1-3/4 x 4 x 10	50-7/8	897	LCC-20-48-30-30
3,000	48	30	30	24	47	39	8-7/8	11-1/4	4	2 x 5 x 10	37-3/4	993	LCC-20-60-36-16
3,000	60	36	30	30	56	48	8-3/4	11-3/4	4	2 x 5 x 10	45-3/4	1,087	LCC-20-60-36-24
3,000	72	42	30	36	65	57	10-1/8	13-5/8	4	2 x 5 x 10	38	1,246	LCC-20-72-42-16
			24	24							46	1,439	LCC-20-72-42-24
			30	30							46-7/8	1,134	LCC-30-48-30-24
			36	36							52-7/8	1,220	LCC-30-48-30-30
			42	42							48	1,462	LCC-30-60-36-24
			48	48							54	1,560	LCC-30-60-36-30
			54	54							49	1,806	LCC-30-72-42-24
			60	60							55	2,007	LCC-30-72-42-30
4,000	48	30	30	24	47	39	9-5/8	12-1/4	4	2-1/4 x 6 x 14	58-1/8	1,511	LCC-40-48-30-30
4,000	60	36	30	30	56	48	10-3/4	13-3/8	4	2-1/4 x 6 x 14	64-1/8	1,618	LCC-40-48-30-36
4,000	72	42	30	36	65	57	11-7/8	14-3/8	4	2-1/4 x 6 x 14	53-1/4	1,827	LCC-40-60-36-24
			30	36							59-1/4	1,951	LCC-40-60-36-30
			36	42							54-3/8	2,244	LCC-40-72-42-24
			42	48							60-3/8	2,381	LCC-40-72-42-30
			48	54							63-7/8	1,761	LCC-50-48-30-30
			54	60							69-7/8	1,886	LCC-50-48-30-36
5,000	48	30	28	24	47	39	10-7/8	13-3/4	4	2-1/2 x 6 x 18	63	2,261	LCC-50-60-36-28
5,000	60	36	34	30	56	48	12	15	4	2-1/2 x 6 x 18	69	2,524	LCC-50-60-36-34
5,000	72	42	32	36	67	57	12-1/2	15-1/4	4	2-1/2 x 6 x 18	59-1/2	2,678	LCC-50-72-42-24
			38	44							67-1/2	2,890	LCC-50-72-42-32
			44	50							63-3/8	2,549	LCC-60-60-36-28
			50	56							69-3/8	2,709	LCC-60-60-36-34
			56	62							64-5/8	3,107	LCC-60-72-42-28
			62	68							70-5/8	3,525	LCC-60-72-42-34
6,000	60	36	38	30	58	48	12-3/8	15-5/8	4-1/2	2-1/2 x 6 x 18	79-1/8	4,587	LCC-80-72-42-38
6,000	72	42	44	36	67	57	13-5/8	16-3/4	4-1/2	2-1/2 x 6 x 18	85-1/8	4,820	LCC-80-72-42-44
8,000	72	42	38	36	69	57	15-1/8	18-3/4	5	3 x 7 x 20	79-1/2	6,594	LCC-100-84-46-38
10,000	84	46	44	42	84	65	15-7/8	19-1/4	5	4 x 7 x 20	85-1/2	6,986	LCC-100-84-46-44

- Lifting arm length allows minimum coil width to be handled w/o protrusion of lift arm past edge of coil.
- All coils must be centered under the lifting bail.
- Please verify that the lifting bail size will suit crane hook.
- Other capacities and lengths available upon request.

**Below the Hook Lifting**

**C-Hook Lifters**

**Model CSC - Close Stacking C-Hooks, High Strength Steel**

The Close Stacking C-hook has a shorter upper arm for handling various coil widths flush against a vertical surface.

Integral lifting bail saves headroom and minimizes inspection normally associated with welded lifting bails.

High strength alloy steel reduces the physical size of the lift arm allowing movement into confined areas for direct crane loading and unloading.

All lifters are proof tested exceeding ANSI/ASME B30.20 standards and test certificate issued. Painted safety yellow and clearly marked on both sides with rated capacity to conform to OSHA standards.

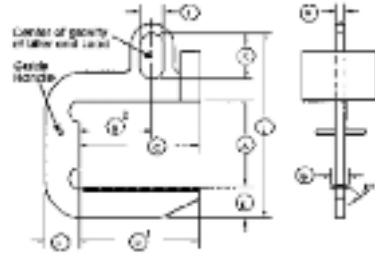

13  
Below the Hook Lifting

Capacity <sup>4</sup> (lbs)	Coil Width		Vertical Clear A (in)	Dist. to Center of Gravity B (in)	Upper Arm Length C (in)	Lift Arm Length D (in)	Lift Arm Depth E (in)	Vertical Post Depth F (in)	Lift Arm Width G (in)	Bail Size <sup>3</sup> H J K (in)	Total Height L (in)	Approx. Lifter Wt. (lbs)	Model No.
	Min. (in)	Max. (in)											
1,000	36	24	18	30	30	5-1/4	8	4	1-1/2 x 4 x 10	34-5/8	432	CSC-10-36-24-16	
	48	30	24	39	39	6-1/8	8-3/4	4	1-1/2 x 4 x 10	42-5/8	499	CSC-10-36-24-24	
	60	36	30	48	48	6-7/8	9-1/2	4	1-1/2 x 4 x 10	35-1/2	527	CSC-10-48-30-16	
2,000	36	24	18	30	30	7-1/4	9-5/8	4	1-3/4 x 4 x 10	43-1/2	642	CSC-10-48-30-24	
	48	30	24	39	39	7-7/8	9-7/8	4	1-3/4 x 4 x 10	35-7/8	749	CSC-10-60-36-16	
	60	36	30	48	48	8-3/4	11-3/4	4	1-3/4 x 4 x 10	43-7/8	823	CSC-10-60-36-24	
3,000	48	30	24	39	39	8-7/8	11-1/4	4	2 x 5 x 10	44-1/4	744	CSC-20-36-24-24	
	60	36	30	48	48	10	12-1/4	4	2 x 5 x 10	50-1/4	959	CSC-20-36-24-30	
	72	42	36	57	57	11	13-1/4	4	2 x 5 x 10	44-7/8	1,083	CSC-20-48-30-24	
4,000	48	30	24	39	39	9-5/8	12-1/4	4	2-1/4 x 6 x 14	50-7/8	1,176	CSC-20-48-30-30	
	60	36	30	48	48	10-3/4	13-3/8	4	2-1/4 x 6 x 14	37-3/4	1,222	CSC-20-60-36-16	
	72	42	36	57	57	11-7/8	14-3/8	4	2-1/4 x 6 x 14	45-3/4	1,353	CSC-20-60-36-24	
5,000	48	30	24	39	39	10-7/8	13-3/4	4	2-1/2 x 6 x 18	38	1,482	CSC-20-72-42-16	
	60	36	30	48	48	12	15	4	2-1/2 x 6 x 18	46	1,730	CSC-20-72-42-24	
	72	42	36	59	57	12-1/2	15-1/4	4	2-1/2 x 6 x 18	46-7/8	1,486	CSC-30-48-30-24	
6,000	48	30	24	39	39	10-7/8	13-3/4	4	2-1/2 x 6 x 18	52-7/8	1,612	CSC-30-48-30-30	
	60	36	30	48	48	12	15	4	2-1/2 x 6 x 18	48	1,831	CSC-30-60-36-24	
	72	42	36	59	57	12-1/2	15-1/4	4	2-1/2 x 6 x 18	49	2,175	CSC-30-60-36-30	
8,000	48	30	24	39	39	10-7/8	13-3/4	4	2-1/4 x 6 x 14	55	2,508	CSC-30-72-42-24	
	60	36	30	48	48	12	15	4	2-1/4 x 6 x 14	58-1/8	2,017	CSC-30-72-42-30	
	72	42	36	59	57	12-1/2	15-1/4	4	2-1/4 x 6 x 14	64-1/8	2,175	CSC-40-48-30-30	
10,000	48	30	24	39	39	10-7/8	13-3/4	4	2-1/4 x 6 x 14	53-1/4	2,307	CSC-40-48-30-36	
	60	36	30	48	48	12	15	4	2-1/4 x 6 x 14	59-1/4	2,590	CSC-40-60-36-24	
	72	42	36	59	57	12-1/2	15-1/4	4	2-1/4 x 6 x 14	63-3/8	2,933	CSC-40-60-36-30	
1,000	36	24	18	30	30	5-1/4	8	4	1-1/2 x 4 x 10	63-3/8	3,047	CSC-50-60-36-28	
	48	30	24	39	39	6-1/8	8-3/4	4	1-1/2 x 4 x 10	69-3/8	3,258	CSC-50-60-36-34	
	60	36	30	48	48	6-7/8	9-1/2	4	1-1/2 x 4 x 10	59-1/2	3,403	CSC-50-72-42-24	
2,000	36	24	18	30	30	7-1/4	9-5/8	4	1-3/4 x 4 x 10	67-1/2	3,704	CSC-50-72-42-30	
	48	30	24	39	39	7-7/8	9-7/8	4	1-3/4 x 4 x 10	63-3/8	3,947	CSC-60-36-28	
	60	36	30	48	48	8-3/4	11-3/4	4	1-3/4 x 4 x 10	69-3/8	3,258	CSC-60-60-36-24	
3,000	48	30	24	39	39	8-7/8	11-1/4	4	2 x 5 x 10	64-5/8	3,517	CSC-60-72-42-28	
	60	36	30	48	48	10	12-1/4	4	2 x 5 x 10	70-5/8	4,011	CSC-60-72-42-34	
	72	42	36	57	57	11	13-1/4	4	2 x 5 x 10	79-1/8	5,025	CSC-80-72-42-38	
4,000	48	30	24	39	39	9-5/8	12-1/4	4	2-1/4 x 6 x 14	85-1/8	5,290	CSC-80-72-42-44	
	60	36	30	48	48	10-3/4	13-3/8	4	2-1/4 x 6 x 14	79-1/2	7,275	CSC-100-84-46-38	
	72	42	36	57	57	11-7/8	14-3/8	4	2-1/4 x 6 x 14	85-1/2	7,617	CSC-100-84-46-44	

- Lifting arm length allows minimum coil width to be handled w/o protrusion of lift arm past edge of coil.
- All coils must be centered under the lifting bail.
- Please verify that the lifting bail size will suit crane hook.
- Other capacities and lengths available upon request.

**PROPER USE OF HOOK-LIFTERS**

The very fact that the use of a lifter is required usually means that a considerable amount of weight is involved. Because this weight can fall and cause damage, more than normal caution

is necessary. These drawings indicate some of the procedures for the use of below-hook lifters. They also indicate the results caused by improper procedures in the use of below-hook

lifters. No responsibility for the safety of the operator is suggested or implied by Hanes Supply, resulting from an improper procedure shown or not shown.

**General Information Before Lifting**



- Lifters should only be used by trained operators.
- Pay attention to what you're doing.
- Test operation of lifters with moving parts at the beginning of each shift.
- Before lifting, make sure hoist rope or chain is free from kinks. Multiple part lines should not be twisted around each other.
- Make a preliminary lift of a few inches to make sure the load is balanced.
- Make sure the load is not too big or too heavy for the lifter.
- Make sure the combined weight of the lifter and the load does not exceed the capacity of the crane.
- Do not pick up hot loads unless the lifter is specifically designed for high temperature service.
- If you are worried about safety REFUSE to make the lift until safety has been assured.

**Moving a Load**



- Take instructions only from the person designated to give signals.
- Make sure there is room for the load to move.
- Stay out from under the load. Make sure other people stay out from under the load.
- Never ride on lifters.
- Guide loads by pushing. CAUTION! With sheet lifters be sure to keep load level. Tilting the lifter could cause the load to slide off the lifter.
- Don't lift the load any higher than necessary. The higher they are the harder they fall.
- Avoid sudden starts and stops. Resulting shock load can stress system far beyond its capability.
- Always set down load before leaving lifter.
- Store the empty lifter in its proper place. They are big & heavy & can cause a lot of damage if they fall over.

## Custom C-Hook Lifters

### Custom Tubular Style C-Hooks

**Model TCF - Close Stacking with flame Cut Lift Arm**  
 Flame cut lift arm allows movement into confined areas

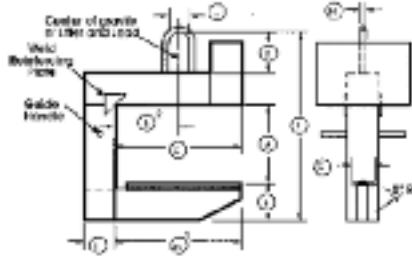

**Model TLC - Low Cost C-Hook**

Longer upper arm reduces counterweight for a lighter weight lifter

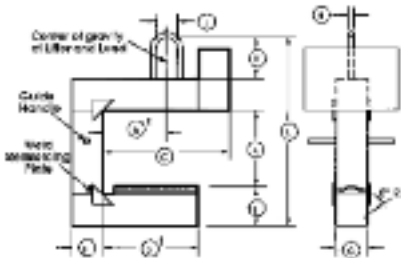

**Model TCS - Close Stacking C-Hook**

Shorter upper arm for handling coils flush against vertical surface

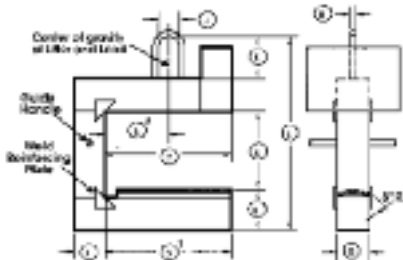

**Model TCF**       **Model TLC**       **Model TCS**

Capacity \_\_\_\_\_ lbs.

- A \_\_\_\_\_ Vertical Clearance
- B \_\_\_\_\_ 1/2 of Max. Coil Width
- C \_\_\_\_\_ Upper Arm Length
- D \_\_\_\_\_ Lift Arm Length
- \*E \_\_\_\_\_ Lift Arm Depth
- \*F \_\_\_\_\_ Vertical Post Depth
- G \_\_\_\_\_ Lift Arm Width
- \*H \_\_\_\_\_ Bail Thk.
- \*J \_\_\_\_\_ Bail Width
- \*K \_\_\_\_\_ Bail Height
- \*L \_\_\_\_\_ Total Height

\* Optional Data

1 Lifting arm length allows min. coil width to be handled w/o protrusion of lift arm past edge of coil.

2 All coils must be centered under the lifting bail.

3 Please verify that the lifting hook bail size will suit crane hook.

Additional Information: \_\_\_\_\_

\_\_\_\_\_

### Custom Plate Style C-Hooks

**Model LCC - Low Cost C-Hook**

Longer Upper Arm reduces counter weight for a lighter weight lifter.

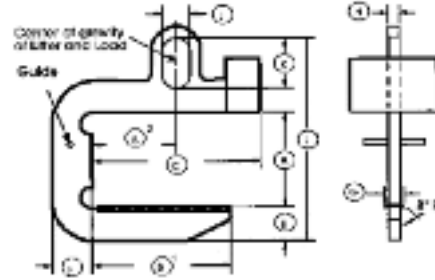

**Model CSC - Close Stacking C-Hook**

Shorter upper arm for handling coils flush against vertical surface.

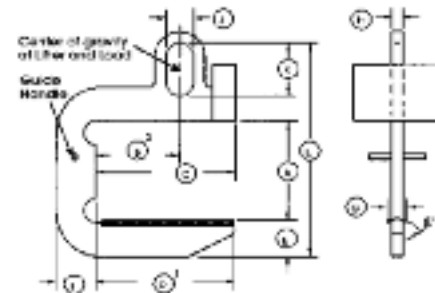

**Model LCC**       **Model CSC**

Capacity \_\_\_\_\_ lbs.

- A \_\_\_\_\_ Vertical Clearance
- B \_\_\_\_\_ 1/2 of Max. Coil Width
- C \_\_\_\_\_ Upper Arm Length
- D \_\_\_\_\_ Lift Arm Length
- \*E \_\_\_\_\_ Lift Arm Depth
- \*F \_\_\_\_\_ Vertical Post Depth
- G \_\_\_\_\_ Lift Arm Width
- \*H \_\_\_\_\_ Bail Thk.
- \*J \_\_\_\_\_ Bail Width
- \*K \_\_\_\_\_ Bail Height
- \*L \_\_\_\_\_ Total Height

\* Optional Data

1 Lifting arm length allows min. coil width to be handled w/o protrusion of lift arm past edge of coil.

2 All coils must be centered under the lifting bail.

3 Please verify that the lifting hook bail size will suit crane hook.

Additional Information: \_\_\_\_\_

\_\_\_\_\_

\_\_\_\_\_

**Below the Hook Lifting**

**Crane Forks**

**Model FCF - Fixed Crane Fork**

The Fixed Crane Fork converts an overhead crane into a maintenance-free low cost fork lift truck that is counterbalanced to hang level for easy insertion under the load.

External weld reinforcing plates strengthens both the weld and tube at critical stress areas.

All lifters are proof tested exceeding ANSI/ASME B30.20 standards and test certificate issued. Painted safety yellow and clearly marked on both sides with rated capacity to conform to OSHA standards.

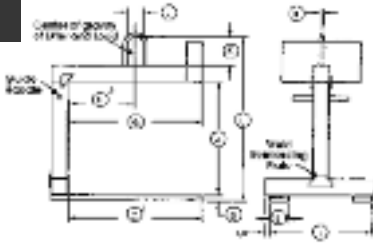

- 1 Fork length is equal to the max. load length.
- 2 All loads must be centered under the lifting bail.
- 3 Please verify that the lifting bail size will suit crane hook.
- 4 Other capacities and load lengths available upon request.

Capacity <sup>4</sup> (lbs)	Max. Load Length (in)	Vertical Clear A (in)	Dist. to Center of Gravity B (in)	Fork Length C (in)	Lift Fork Size D   E (in)	Outside Width F (in)	Arm Upper Length G (in)	Bail Size <sup>3</sup> H J K (in)	Total Height L (in)	Approx. Lifter Wt. (lbs)	Model No.
1,000	30	48	15	30	1-1/4 x 4	24	30	3/4 x 2 x 4	56-1/4	231	FCF-1-30-48
1,000	36	48	18	36	1-1/4 x 4	24	36	3/4 x 2 x 4	56-1/4	252	FCF-1-36-48
1,000	42	48	21	42	1-1/4 x 4	24	42	3/4 x 2 x 4	56-1/4	271	FCF-1-42-48
1,000	48	48	24	48	1-1/4 x 4	24	48	3/4 x 2 x 4	56-1/4	355	FCF-1-48-48
2,000	30	48	15	30	1-1/2 x 4	24	30	3/4 x 2 x 4	57-1/2	318	FCF-2-30-48
2,000	36	48	18	36	1-1/2 x 4	24	36	3/4 x 2 x 4	57-1/2	340	FCF-2-36-48
2,000	42	48	21	42	1-1/2 x 4	24	42	3/4 x 2 x 4	57-1/2	363	FCF-2-42-48
2,000	48	48	24	48	1-1/2 x 4	24	48	3/4 x 2 x 4	57-1/2	450	FCF-2-48-48
3,000	36	48	18	36	1-3/4 x 4	24	36	1 x 2 x 4	59-3/4	452	FCF-3-36-48
3,000	42	48	21	42	1-3/4 x 4	24	42	1 x 2 x 4	59-3/4	478	FCF-3-42-48
3,000	48	48	24	48	1-3/4 x 4	24	48	1 x 2 x 4	59-3/4	505	FCF-3-48-48
4,000	36	48	18	36	1-3/4 x 4	24	36	1 x 2 x 4	59-3/4	519	FCF-4-36-48
4,000	42	48	21	42	1-3/4 x 4	24	42	1 x 2 x 4	59-3/4	544	FCF-4-42-48
4,000	48	48	24	48	1-3/4 x 4	24	48	1 x 2 x 4	59-3/4	571	FCF-4-48-48
6,000	36	48	18	36	1-3/4 x 4	26	36	1-1/2 x 4 x 6	61-3/4	606	FCF-6-36-48
6,000	42	48	21	42	2 x 4	26	42	1-1/2 x 4 x 6	64	683	FCF-6-42-48
6,000	48	48	24	48	2 x 4	26	48	1-1/2 x 4 x 6	64	712	FCF-6-48-48
6,000	60	60	30	60	2-1/2 x 4	32	60	1-1/2 x 4 x 6	76-1/2	1,057	FCF-6-60-60
8,000	42	48	21	42	2 x 4-1/2	28	42	1-1/2 x 4 x 8	66	799	FCF-8-42-48
8,000	48	48	24	48	2-1/2 x 4	28	48	1-1/2 x 4 x 8	66-1/2	889	FCF-8-48-48
8,000	60	60	30	60	2-1/2 x 4	32	60	1-1/2 x 4 x 8	78-1/2	1,214	FCF-8-60-60
8,000	72	72	36	72	2-1/2 x 5	36	72	1-1/2 x 4 x 8	92-1/2	1,654	FCF-8-72-72
10,000	48	48	24	48	2-1/2 x 4	32	48	1-3/4 x 4 x 10	68-1/2	1,219	FCF-10-48-48
10,000	60	60	30	60	2-1/2 x 5	32	60	1-3/4 x 4 x 10	82-1/2	1,514	FCF-10-60-60
10,000	72	72	36	72	2-1/2 x 6	36	72	1-3/4 x 4 x 10	94-1/2	1,893	FCF-10-72-72
15,000	48	48	24	48	2-3/4 x 5	32	48	1-3/4 x 5 x 10	70-3/4	1,453	FCF-15-48-48
15,000	60	60	30	60	2-3/4 x 6	32	60	1-3/4 x 5 x 10	82-3/4	2,117	FCF-15-60-60
15,000	72	72	36	72	2-3/4 x 7	36	72	1-3/4 x 5 x 10	94-3/4	2,539	FCF-15-72-72
20,000	48	48	24	48	2-3/4 x 6	32	48	1-3/4 x 5 x 10	70-3/4	1,913	FCF-20-48-48
20,000	60	60	30	60	2-3/4 x 8	32	60	1-3/4 x 5 x 10	82-3/4	2,991	FCF-20-60-60
20,000	72	72	36	72	2-3/4 x 10	36	72	1-3/4 x 5 x 10	98-3/4	3,744	FCF-20-72-72
30,000	72	72	36	72	4 x 8-3/4	42	72	1-3/4 x 6 x 14	106	4,894	FCF-30-72-72
40,000	72	72	36	72	4 x 10-1/2	42	72	1-3/4 x 6 x 14	106	5,950	FCF-40-72-72
50,000	72	72	36	72	4 x 13	42	72	2 x 6 x 18	110	6,978	FCF-50-72-72

**Model ACF - Adjustable Crane Fork**

The Adjustable Crane Fork converts an overhead crane into a low cost fork lift truck that can handle various widths and is counterbalanced to hang level for easy insertion under the load.

External weld reinforcing plates strengthens both the weld and tube at critical stress areas.

All lifters are proof tested exceeding ANSI/ASME B30.20 standards and test certificate issued. Painted safety yellow and clearly marked on both sides with rated capacity to conform to OSHA standards.

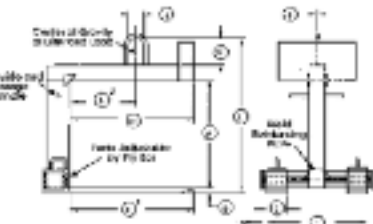

- 1 Fork length is equal to the max. load length.
- 2 All loads must be centered under the lifting bail.
- 3 Please verify that the lifting bail size will suit crane hook.
- 4 Other capacities and load lengths available upon request.

Capacity <sup>4</sup> (lbs)	Max. Load Length (in)	Vertical Clear A (in)	Dist. to Center of Gravity B (in)	Fork Length C (in)	Lift Fork Size D   E (in)	Outside Width F (in)	Arm Upper Length G (in)	Bail Size <sup>3</sup> H J K (in)	Total Height L (in)	Approx. Lifter Wt. (lbs)	Model No.
1,000	30	48	15	30	1-1/4 x 4	14	36	3/4 x 2 x 4	56-1/4	249	ACF-1-30-48
1,000	36	48	18	36	1-1/4 x 4	14	36	3/4 x 2 x 4	56-1/4	272	ACF-1-36-48
1,000	42	48	21	42	1-1/4 x 4	14	36	3/4 x 2 x 4	56-1/4	293	ACF-1-42-48
1,000	48	48	24	48	1-1/4 x 4	15	36	3/4 x 2 x 4	56-1/4	383	ACF-1-48-48
2,000	30	48	15	30	1-1/2 x 4	15	36	3/4 x 2 x 4	57-1/2	343	ACF-2-30-48
2,000	36	48	18	36	1-1/2 x 4	15	36	3/4 x 2 x 4	57-1/2	367	ACF-2-36-48
2,000	42	48	21	42	1-1/2 x 4	15	36	3/4 x 2 x 4	57-1/2	392	ACF-2-42-48
2,000	48	48	24	48	1-1/2 x 4	15	36	3/4 x 2 x 4	57-1/2	486	ACF-2-48-48
3,000	36	48	18	36	1-3/4 x 4	15	38	1 x 2 x 4	59-3/4	488	ACF-3-36-48
3,000	42	48	21	42	1-3/4 x 4	15	38	1 x 2 x 4	59-3/4	516	ACF-3-42-48
3,000	48	48	24	48	1-3/4 x 4	15	38	1 x 2 x 4	59-3/4	548	ACF-3-48-48
4,000	36	48	18	36	1-3/4 x 4	15	38	1 x 2 x 4	59-3/4	565	ACF-4-36-48
4,000	42	48	21	42	1-3/4 x 4	17	38	1 x 2 x 4	59-3/4	595	ACF-4-42-48
4,000	48	48	24	48	1-3/4 x 4	17	38	1 x 2 x 4	59-3/4	624	ACF-4-48-48
6,000	36	48	18	36	1-3/4 x 4	17	38	1-1/2 x 4 x 6	61-3/4	660	ACF-6-36-48
6,000	42	48	21	42	2 x 4	17	38	1-1/2 x 4 x 6	64	734	ACF-6-42-48
6,000	48	48	24	48	2 x 4	17	38	1-1/2 x 4 x 6	64	771	ACF-6-48-48
6,000	60	60	30	60	2-1/2 x 4	20	42	1-1/2 x 4 x 6	76-1/2	1,141	ACF-6-60-60
8,000	42	48	21	42	2 x 4-1/2	20	42	1-1/2 x 4 x 8	66	863	ACF-8-42-48
8,000	48	48	24	48	2-1/2 x 4	20	42	1-1/2 x 4 x 8	66-1/2	963	ACF-8-48-48
8,000	60	60	30	60	2-1/2 x 4	20	48	1-1/2 x 4 x 8	78-1/2	1,340	ACF-8-60-60
8,000	72	72	36	72	2-1/2 x 5	21	48	1-1/2 x 4 x 8	92-1/2	1,780	ACF-8-72-72
10,000	48	48	24	48	2-1/2 x 4	20	42	1-3/4 x 4 x 10	68-1/2	1,316	ACF-10-48-48
10,000	60	60	30	60	2-1/2 x 5	22	48	1-3/4 x 4 x 10	82-1/2	1,642	ACF-10-60-60
10,000	72	72	36	72	2-1/2 x 6	26	48	1-3/4 x 4 x 10	94-1/2	2,044	ACF-10-72-72
15,000	48	48	24	48	2-3/4 x 5	24	48	1-3/4 x 5 x 10	70-3/4	1,570	ACF-15-48-48
15,000	60	60	30	60	2-3/4 x 6	26	48	1-3/4 x 5 x 10	82-3/4	2,297	ACF-15-60-60
15,000	72	72	36	72	2-3/4 x 7	28	54	1-3/4 x 5 x 10	94-3/4	2,742	ACF-15-72-72
20,000	48	48	24	48	2-3/4 x 6	26	48	1-3/4 x 5 x 10	70-3/4	2,066	ACF-20-48-48
20,000	60	60	30	60	2-3/4 x 8	30	48	1-3/4 x 5 x 10	82-3/4	3,229	ACF-20-60-60
20,000	72	72	36	72	2-3/4 x 10	33	54	1-3/4 x 5 x 10	98-3/4	4,044	ACF-20-72-72
30,000	72	72	36	72	4 x 8-3/4	33	54	1-3/4 x 6 x 14	106	5,280	ACF-30-72-72
40,000	72	72	36	72	4 x 10-1/2	36	54	1-3/4 x 6 x 14	106	6,426	ACF-40-72-72
50,000	72	72	36	72	4 x 13	45	60	2 x 6 x 18	110	7,566	ACF-50-72-72

**13**  
Below the Hook Lifting

## Custom Crane Forks

### Custom Crane Forks

#### Model FCF - Fixed Crane Fork

Converts an overhead crane into a low-cost fork lift truck

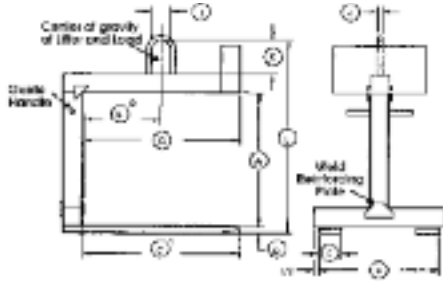

#### Model ACF - Adjustable Crane Fork

Adjustable forks allows handling of various size bundles

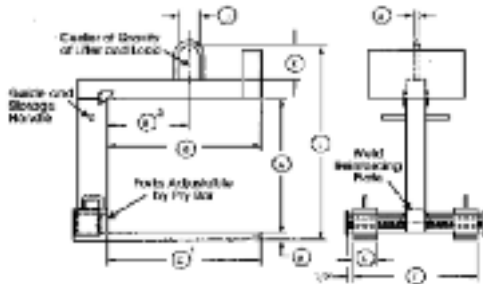

#### Model FCF □ Model ACF □

Capacity \_\_\_\_\_ lbs.

- A \_\_\_\_\_ Vertical Clearance
- B \_\_\_\_\_ 1/2 of Max. Pallet Length
- C \_\_\_\_\_ Fork Length
- D \_\_\_\_\_ Fork Thickness
- \*E \_\_\_\_\_ Fork Width
- \*F \_\_\_\_\_ Outside Width
- G \_\_\_\_\_ Upper Arm Length
- \*H \_\_\_\_\_ Bail Thk.
- \*J \_\_\_\_\_ Bail Width
- \*K \_\_\_\_\_ Bail Height
- \*L \_\_\_\_\_ Total Height

\* Optional Data

- 1 Fork length is equal to the max. pallet load length.
- 2 All loads must be centered under the lifting bail.
- 3 Please verify that the lifting bail size will suit crane hook.

Additional Information: \_\_\_\_\_

\_\_\_\_\_

\_\_\_\_\_

\_\_\_\_\_

## Sheet Lifters

### Model TSL Telescoping Sheet Lifter

We offer a versatile sheet lifter that can handle bundles of sheet metal, crates, palletized products and more with few modifications to its structure.

Drive system consists of worm and worm gear assembly to prevent side forces from opening the legs when loaded.

Our telescoping sheet lifter has a heavy duty construction to withstand rugged conditions and provide years of service with very low maintenance.

All lifters are proof tested exceeding ANSI/ASME B30.20 standards and test certificate issued. Painted safety yellow and clearly marked on both sides with rated capacity to conform to OSHA standards.

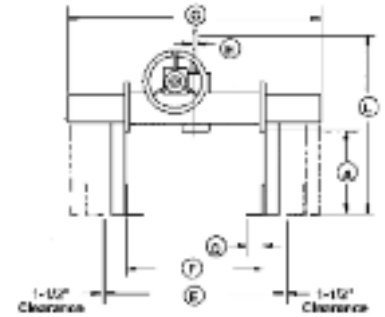
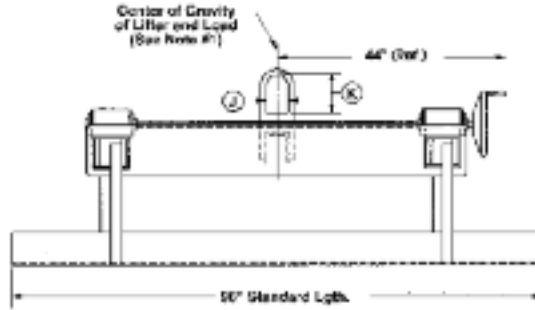

#### Custom Telescoping Sheet Lifter

Model TSL □ Capacity \_\_\_\_\_ lbs.

- A \_\_\_\_\_ Vertical Clearance
- \*D \_\_\_\_\_ Support Width
- E \_\_\_\_\_ Max. Bundle Width
- F \_\_\_\_\_ Min. Bundle Width
- \*H \_\_\_\_\_ Bail Thickness
- \*J \_\_\_\_\_ Bail Width
- \*K \_\_\_\_\_ Bail Height
- \*L \_\_\_\_\_ Total Height
- M \_\_\_\_\_ Length of Carrying Angle

\* Optional Data

- 1 All loads must be centered under the lifting bail.
- 2 Please verify that the lifting bail size will suit crane hook.
- 3 Modifications and other accessories are available upon request.

Additional Information: \_\_\_\_\_

\_\_\_\_\_

\_\_\_\_\_

Capacity (lbs)	Bundle Width		Vertical Clear. A (in)	Bail Size <sup>2</sup> H J K (in)			Support Width D (in)	Max. Width in Closed Position G (in)	Total Height L (in)	Approx. Lifter Wt. (lbs)	Model No.
	E Max. (in)	F Min. (in)		H	J	K					
6000	60	20	16	1-1/4	4	8	3-1/8	70	38	1055	TSL-6-60-20-16
6000	72	24	16	1-1/4	4	8	3-1/8	82	38	1108	TSL-6-72-24-16
10000	60	20	16	1-1/4	4	10	3-1/8	70	40	1094	TSL-10-60-20-16
10000	72	24	16	1-1/4	4	10	3-1/8	82	40	1150	TSL-10-72-24-16
10000	96	36	16	1-1/4	4	10	5-5/8	99	40	1421	TSL-10-96-36-16
20000	60	20	16	1-1/4	4	10	3-1/8	70	40	1254	TSL-20-60-20-16
20000	72	24	16	1-1/4	4	10	3-1/8	82	40	1317	TSL-20-72-24-16
20000	96	36	16	1-1/4	4	10	5-5/8	99	40	1960	TSL-20-96-36-16
30000	72	24	18	1-3/4	6	14	5-1/2	87	46	2102	TSL-30-72-24-18
30000	96	36	18	1-3/4	6	14	5-1/2	99	46	2410	TSL-30-96-36-18
40000	72	24	18	1-3/4	6	14	5-1/2	87	46	2372	TSL-40-72-24-18
40000	96	36	18	1-3/4	6	14	5-1/2	99	46	2795	TSL-40-96-36-18

<sup>1</sup> All loads must be centered under the lifting bail.

<sup>2</sup> Please verify that the lifting bail size will suit crane hook.

<sup>3</sup> Modifications and other accessories are available upon request.

**Below the Hook Lifting**

**Coil Lifters**

**Model NAC - Narrow Aisle Coil Lifter**

Our narrow aisle coil lifter is the ideal solution to handling and positioning coils close together. Coils can be handled with aisles as narrow as 18".

Integral lifting bail saves headroom and minimizes inspection normally associated with welded lifting bails. Upper beam and down legs are made of high strength alloy steel reducing the physical size of the lifter.

Marked notches and built-in parking stand on upper beam allows for easy adjustment of down

legs for specific coil widths.

The edges of the down legs have a radius for easy maneuvering of legs into inside of coil. Lifting bail has a radius on the upper portion to prevent damage to the crane hook.

All lifters are proof tested exceeding ANSI/ASME B30.20 standards and test certificate issued. Painted safety yellow and clearly marked on both sides with rated capacity to conform to OSHA standards.

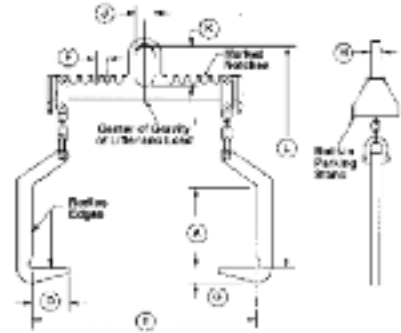

**Custom Narrow Aisle Coil Lifter**

**Model NAC** □ Capacity \_\_\_\_\_ lbs.

- A** \_\_\_\_\_ Vertical Clearance
- \*D** \_\_\_\_\_ Support Length
- E<sup>1</sup>** \_\_\_\_\_ Max. Coil Width
- E<sup>2</sup>** \_\_\_\_\_ Min. Coil Width
- \*F** \_\_\_\_\_ Adjustable Spacing
- \*G** \_\_\_\_\_ Support Depth
- \*H** \_\_\_\_\_ Bail Thickness
- \*J** \_\_\_\_\_ Bail Width
- \*K** \_\_\_\_\_ Bail Height
- \*L** \_\_\_\_\_ Total Height

\* Optional Data

Additional Information: \_\_\_\_\_

Capacity (lbs)	Coil Width		Clear. A (in)	Vertical Bail Size <sup>2</sup>			Support Length D (in)	Support Depth G (in)	Adjust. Spacing F (in)	Total Height L (in)	Approx. Lifter Wt. (lbs)	Model No.
	Max. (in)	Min. (in)		H	J	K						
20,000	48	20	24	1-1/4	4	8	8	4	2	62	378	NAC-20-48-20-24
20,000	60	24	24	1-1/4	4	8	8	4	2	62	454	NAC-20-60-24-24
20,000	72	24	24	1-1/4	4	8	8	4	2	62	515	NAC-20-72-24-24
30,000	48	20	28	1-1/2	4	10	8	4-1/4	3	69-7/8	492	NAC-30-48-20-28
30,000	60	24	28	1-1/2	4	10	8	4-1/4	3	69-7/8	577	NAC-30-60-24-28
30,000	72	24	28	1-1/2	4	10	8	4-1/4	3	69-7/8	661	NAC-30-72-24-28
40,000	48	20	32	1-3/4	5	10	10	4-1/2	3	79-1/2	680	NAC-40-48-20-32
40,000	60	24	32	1-3/4	5	10	10	4-1/2	3	79-1/2	767	NAC-40-60-24-32
40,000	72	24	32	1-3/4	5	10	10	4-1/2	3	79-1/2	890	NAC-40-72-24-32
40,000	84	24	32	1-3/4	5	10	10	4-1/2	3	79-1/2	932	NAC-40-84-24-32
50,000	60	24	34	2	6	14	10	4-3/4	3	83-3/4	887	NAC-50-60-24-34
50,000	72	24	34	2	6	14	10	4-3/4	3	83-3/4	1,006	NAC-50-72-24-34
50,000	84	24	34	2	6	14	10	4-3/4	3	83-3/4	1,046	NAC-50-84-24-34
50,000	96	36	34	2	6	14	10	4-3/4	3	83-3/4	1,180	NAC-50-96-36-34
60,000	60	24	34	2-1/4	6	14	10	5	3	89-1/4	1,066	NAC-60-60-24-34
60,000	72	24	34	2-1/4	6	14	10	5	3	89-1/4	1,217	NAC-60-72-24-34
60,000	84	24	34	2-1/4	6	14	10	5	3	89-1/4	1,310	NAC-60-84-24-34
60,000	96	36	34	2-1/4	6	14	10	5	3	89-1/4	1,546	NAC-60-96-36-34
80,000	72	24	36	2-1/2	6	14	10	5-1/2	3	94-5/8	1,514	NAC-80-72-24-36
80,000	96	36	36	2-1/2	6	14	10	5-1/2	3	94-5/8	1,710	NAC-80-96-36-36

<sup>1</sup> All loads must be centered under the lifting bail. <sup>2</sup> Please verify that the lifting bail size will suit crane hook.

<sup>3</sup> Modifications and other accessories are available upon request.

**Model H - Dixon Coil Hook**

- Easy horizontal to vertical up-ending of coils.
- Pivoting wedge for easy tilting of stacked coils.
- Wedge acts as retainer.
- Efficient and easy to use.
- Popular for use with small, light weight coils.
- For use where overhead clearance is limited.
- Specially designed heat treated pivoting wedge.
- Designed and manufactured to ASME B30.20.

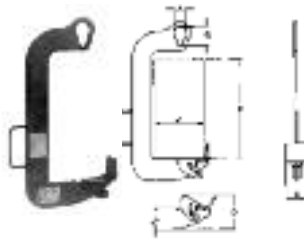

Capacity (Tons)	Catalog No.	Diameter (in)							Wt. (lbs)
		Max. Width. W	Max. Radial R	Min. I.D.	A	B	C	D	
1/2	H10-6-13	6	13	9	2	2-3/4	3-1/2	6	10
1/2	H10-12-13	12	13	9	2	2-3/4	3-1/2	6	20
1	H20-8-16	8	16	10	2	2-3/4	3-1/2	6	22
2	H40-10-18	10	18	12-1/2	2-1/2	3-1/2	2	6-3/4	45
3-1/2	H70-12-20	12	20	14-1/2	3-1/4	5	2-1/2	7-3/4	65

Other sizes available, call Hanes Supply.

Easy Horizontal to vertical movement. Do Not use for vertical to horizontal movement.



Providing spacer blocks between stacked coils permits easy insertion of the wedge. Light weight and pivoting wedge makes it easy to position the hook.

With the hook in place, the wedge pivots as the lift is started, and the coil begins to turn to a vertical position for transporting it.

Coil is in vertical position after being lifted from its pallet. The weight of the coil holds the pivoting wedge in the vertical position during transportation.

Coil being loaded on a stock reel. Hook is easily removed from the coil after releasing the hoist.

**Model G - Dixon Coil Grab**

- Horizontal to vertical and vertical to horizontal movement.
- Clamp and lock onto all four sides of coil.
- Wedge separates stacked coils (do not need spacer blocks).
- T-pins for changing suspension point for wider coils to hang level.
- Compact and lightweight.
- Convenient handling of narrow coils.
- One man operation.
- Prevents coil damage when lifting.
- Locking feature holds grab open when positioning.
- Designed and manufactured to ASME B30.20.

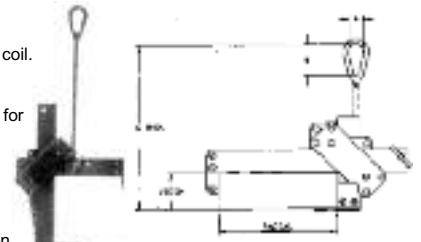

Capacity (Tons)	Catalog No.	Diameter (in)					
		Coil Specs		A	B	C	Wt. (lbs)
		Width Range	Radial Range				
1/2	G10-4-13	1 - 4	3-1/2 - 13	1-3/4	3-1/2	42	28
1	G20-9-12	2-1/2 - 9	3-1/2 - 12	1-3/4	3-1/2	48	30

Horizontal to vertical or vertical to horizontal movement.



The grab is placed on the coil near the binding strap where the wedge can easily enter and separate the coils. As soon as the lift begins, the jaws close on the coil automatically.

The grab has adjusted to the coil size and the jaws have closed on all four sides. As the coil is picked up, it takes a vertical position for transporting.

The coil has now been raised from its pallet and is firmly clamped for transporting and placing on a reel.

When stacking coils, the T-pin for changing the suspension point is positioned so the coil hangs at an angle for lowering to a horizontal position.

# Grabs

## Tong Grabs

LARGE, SMALL, SHORT OR LONG... materials having symmetrical sides may be lifted and transported by one of the Bushman Mechanical type tongs.

COILS OF STEEL, ALUMINUM, BRASS, ETC... paper rolls, bars, ingots and bales are typical examples of materials for which tong grabs are readily designed.

VARIATIONS OF STYLES... gripping ratios and grip pad material are specifically designed to suit the numerous varieties and sizes of materials.

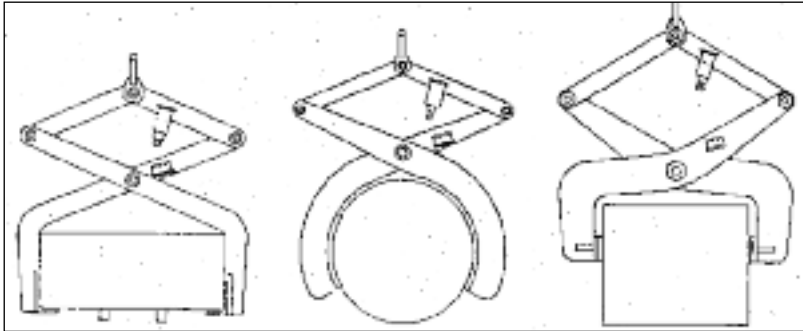

**Fig. I. SUPPORTING TONG**  
Material elevated to allow grab to support load.

**Fig. II GRIPPING TONG**  
Material gripped in the tong yet Outside diameter supported below center for additional holding advantage.

**Fig. III PRESSURE TONG**  
Maximum gripping ratio required to maintain safe hold on vertical sides during lift.

**Supporting tong** shown in **Figure I** is limited to constant sizes of material to maintain a horizontal plane of the lifting feet.

**Gripping Tong** shown in **Figure II** is designed to lift such typical products as coils, rolls, tube etc. The diameter range may vary by approximately 25%. The length variation is almost unlimited as the tong is specifically designed to suit.

**Pressure Tong** shown in **Fig. III** is special in its requirement of grip ratios and pad material to properly suit the material to be lifted. Ingots, bales and other straight sided materials require a sufficient coefficient of friction between the material and grip pads to be safely lifted. Grip pad material may be rubber, steel, belting, points etc.

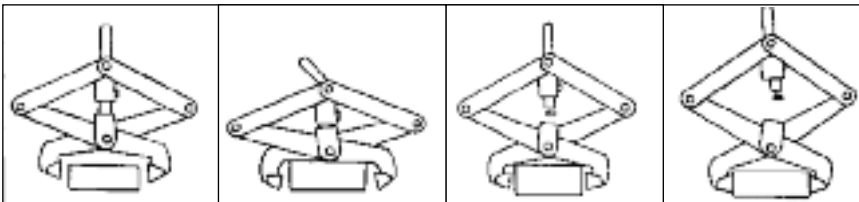

**A** Latch has grab locked in open position.

**B** With grab rested on material and hoist tension relieved, latch automatically disengages from locked position.

**C** Raise hoist to allow grab pads to close onto material.

**D** To release load, lower grab and material to ground or stack. Allow hoist to lower and again relieve tension. Latch will automatically relock grab in open Position.

## Required Information

### Object Data:

Shape \_\_\_\_\_  
 Type of Mat'l \_\_\_\_\_  
 Dimensions:           Min.           Max.  
 L.Length           \_\_\_\_\_ "           \_\_\_\_\_ "  
 W.Width           \_\_\_\_\_ "           \_\_\_\_\_ "  
 H.Height           \_\_\_\_\_ "           \_\_\_\_\_ "  
 OD                   \_\_\_\_\_ "           \_\_\_\_\_ "  
 Pick up on L \_\_\_\_\_ W \_\_\_\_\_ OD \_\_\_\_\_

### Hoist Hook Data:

Dim. D \_\_\_\_\_ "  
 Dim. E \_\_\_\_\_ "  
 Dim. F \_\_\_\_\_ "  
 Dim. G \_\_\_\_\_ "  
 Dim. H \_\_\_\_\_ "  
 Dim. K \_\_\_\_\_ "  
 Dim. L \_\_\_\_\_ "

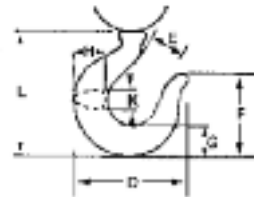

Hook Capacity \_\_\_\_\_ Ton  
 \_\_\_\_\_ Mfr.

## Model 73 & 74 - Barrier Grabs

- Hands-off operation. No need to attach and secure lifting chains or slings.
- The barrier suffers far less damage when moving. This means longer barrier life and less cost.
- The grab is able to move barriers quicker and easier than manual methods, resulting in less man-hours.
- There is no need to drill holes in the barriers to accommodate chains or slings.
- Replaceable urethane lifting pads are standard.
- Designed and manufactured to ASME B30.20.

Model No.	Rated Capacity (lbs)	Wt. (lbs)
"Jersey" barrier - 6" (nominal) width at top		
73 - 4-1/4	8,500	215
73 - 7-1/4	14,500	260
"Southern" barrier - 11" (nominal) width at top		
74 - 4-1/4	8,500	270
74 - 7-1/4	14,500	310

Note 1: "Southern" barrier - states of GA & TN, use exclusively.

Note 2: States of CA, OR & WA may require special grips with steel "Dog Points" in lieu of standard pads. Specify "Dog Points" with order.

• Always supply dimensions A, B & C to insure proper lift.

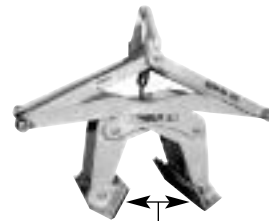

Replaceable Urethane Lifting Pads

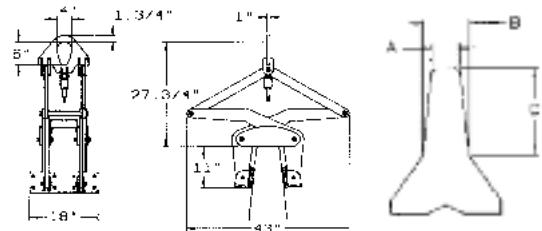

**Below the Hook Lifting**

**Tongs, Pipe & Container Lifters**

**Barrier-Lift**

**Now available with Automatic Actuator**

The Barrier-Lift is now available in a fully automatic mode that allows for hands-free barrier movement. The ratcheting-cam action locks the lifter in the open position. When the Barrier-Lift is set on the barrier, the ratcheting-cam turns 90 degrees and allows the lifter to grip the barrier.

**The Barrier-Lifter:**

- Provides for easy, safe and efficient placement of concrete median barriers.
- Can be used in inclement weather including rain.
- Exclusive custom-made gripper pads made of elastomer molded to steel plate will outperform all other pad surfaces currently in use.
- The custom-made gripper pads provide:
  - Excellent wear/abrasion resistance
  - Superior gripping ability
  - Full surface contact without scratching or damaging concrete
  - Barriers won't slip even when wet

This Barrier-Lift is the largest, most powerful barrier lifter on the market. Intentionally overbuilt to withstand the rigors of the toughest highway construction site. When you're ready to move barriers... get the strongest, most durable barrier lifter available anywhere.

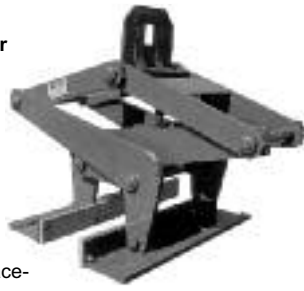

Model No.	Weight (lbs)	Capacity (lbs)	Usage
KL 1500	200	1,500	Concrete Curbing
KL 9000	600	9,000	10' - 16' Barrier Wall
KL 12000	800	12,000	16' - 20' Barrier Wall
KL 15000	1,100	15,000	20' - 30' Barrier Wall
KL 20000	1,400	20,000	30' - 40' Barrier Wall
KL 40000	4,000	40,000	30' - 40' Custom Wall

**Model 111 - Beam Tongs**

- Tong leverage exerts an ever tightening grip on the beam flange.
- Tong provided with lifting shackle.
- Load must be balanced and controlled when lifting.
- May be used in pairs in conjunction with a spreader beam.
- Designed and manufactured to ASME B30.20.



Model No.	Rated Cap (Tons)	Dimensions (in)			Wt. (lbs)
		Beam Width Min. - Max.		A	
111-1	1	5 - 6		17	15
111-2	2	6-1/2 - 8		19	18
111-3	3	7-1/2 - 10		19	21

**Model 172 - Slab Tongs**

- Designed for lifting heavy slabs of concrete, stone or highly polished metal sheets that must be protected from scratching or marring.
- Can be used in construction work to position slabs.
- The curved pads give proper contact for gripping smooth surfaces and handling a large range of sizes.
- Urethane gripping surfaces of the tongs are standard.
- Semi-automatic latch is standard and serves as an aid in positioning the tongs for picking-up the load.
- Designed and manufactured to ASME B30.20.



Model No.	Rated Cap. (lbs)	Load Width (in)	Dim. A (in)	Wt. (lbs)
172-1	1,000	6 - 10	24	50
172-2	1,500	8 - 12	28	70
172-3	1,500	10 - 14	32	90
172-4	1,500	14 - 18	36	120
172-5	1,500	18 - 22	40	150

**Model 109 - Rail Tongs**

- Rail Tongs are designed to handle all standard size rails.
- Tongs are provided with non-slip machined diamond face gripping pad.
- Load must be balanced and controlled when lifting.
- Designed and manufactured to ASME B30.20.



Model No.	Rated Cap. (tons)	A (in)	B (in)	Wt. (lbs)
109-1	1	3	18	15
109-2	2	5	20	18

**Model 77 - Bale Lifting Tongs**

- Lifts bales of paper, cotton, and other materials.
- Wide gripping surface for load stability.
- Includes auto-latching mechanism for one person operation.
- Designed and manufactured to ASME B30.20.



Model No.	Rated Cap. (tons)	Bail Width	Unit Height	Pad Dim's Width	Height	Wt. (lbs.)
77-1/2-36	1/2	36	40	18	9	80
77-1/2-48	1/2	48	46	18	9	85
77-1-36	1	36	40	18	9	90
77-1-48	1	48	46	18	9	95

**Model PC - "Tea Cup" Pipe Carrier**

- An efficient way to handle concrete, water & sewer pipers.
- The Caldwell "Tea Cup" Carrier will save you time & money.
- Three sizes available, to handle from 3/4" to 1-1/2" cable, and lift up to 15 tons.
- Designed & manufactured to ASME B30.20 & B30.9.



PC Model No.	Sling Dia. (in)	Rated Capacity (tons)	Dimensions (in)						
			A	B	C	D	E	F	G
PC-3/4	3/4 7/8	4.9	5-9/16	2	2-1/8	1-1/8	4-11/16	1-7/8	1-1/8
PC-1	1 1-1/8 1-1/4	8.5	6	2-1/2	2-5/8	1-3/8	5-5/8	2	1-3/8
PC-1-1/2	1-1/2	15.0	8	3	3-1/4	1-5/8	7-5/8	3	1-5/8

LS Model No.	Sling Dia. (in)	Std. Length (tons)	After Swage Dim. (in)	
			A	B
LS-3/4	3/4	5	3.25	1.55
LS-7/8	7/8	5	3.86	1.80
LS-1	1	5	4.36	2.05
LS-1-1/8	1-1/8	5	4.81	2.30
LS-1-1/4	1-1/4	5	5.42	2.56
LS-1-1/2	1-1/2	5	6.52	3.00

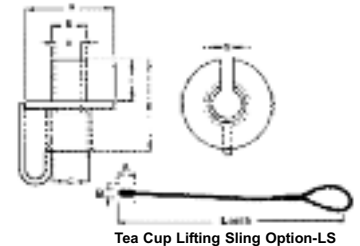

Tea Cup Lifting Sling Option-LS

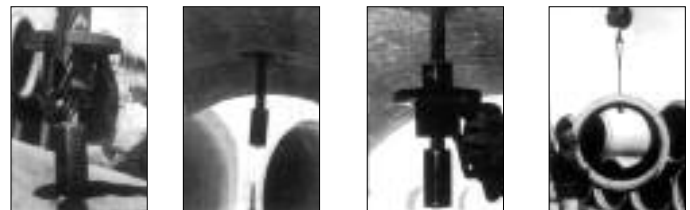

1. Drop pipe carrier lifting sling through hole in pipe.
2. Align and insert "tea cup" pipe carrier into lifting sling.
3. Lift pipe.

13  
Below the Hook Lifting



# Container Lifters

## Model LL - "Corky" Container Lifting Lug

- An efficient way to lift containers.
- 34 ton capacity with 4 "Corky" lugs.
- Latch is resistant to dirt, concrete, and ice.
- Color identified to Separate left and right handed "Corky" lugs.
- Handle indicator shows lug is fully engaged for lift.
- Conforms to use with ASME B30.9 sling capacities.

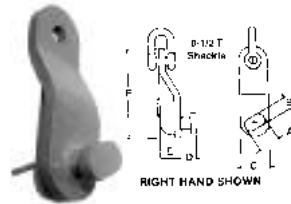

**OPTION:** 8-1/2 ton shackle code-S.

Model No.	Rated Capacity (tons)	Corky Hook Dimensions (in)						Wt. (lbs)	Color	
		A	B	C	D	E	F		Right Hand	Left Hand
LL	8-1/2	3	1-3/4	4	2	2-7/8	12-3/4	17	Yellow	Red

**NOTE:** Specify complete set of 4 (2R & 2L) or individual pieces by L (left) or R (right)



Align Corky Hook with cargo container lift fitting

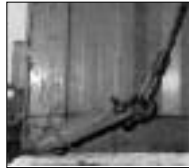

Insert Corky Hook into the lift fitting slot.



Apply tension to the choker cable. Indicator shows lug in locked position.

### Container Lifting Slings with Corky Hooks

Model No.	Container Size (ft)	Sling Length (ft)	Wire Rope (in)	Wire Rope Angle (degrees)	Head Room Req'd (ft/in)
<b>Standard Wire Rope Slings</b>					
CLS-20	20	38	7/8	30	9'6"
CLS-40	40	55	1	45	12'6"
<b>Model 54-24 Adjust-A-Leg</b>					
CLS-24	20	32	3/4	37-1/2	6'6"
CLS-44	40	54	3/4	45	13'6"

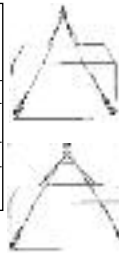

**Std. Wire Rope Slings** - For use with balanced loads. Max. capacity 22-1/2 tons.  
 \*Assembly consists of 2 wire rope slings w/ thimbles & 4 four 8-1/2 ton screw pin anchor shackles.

**Model 54-24 Adjust-A-Leg® Slings** - For use with unbalanced loads. Max. capacity 24 tons.  
 \*Assembly consists of T54-24 Top Assembly, two 3/4" double wire rope slings w/ thimbles & four 8-1/2 ton screw pin anchor shackles.

## Model PPP - Pin Puller

### Product Features:

- Fast and easy way to remove form pins
- Quickly attaches to a lifting hook or shackle
- No parts that could get lost

Model No.	Wt. (lbs)
PPP-1	23



## CONTAINER PROFILE SLING

### Low Profile Sling

#### Bottom Lift ISO Type Container Sling

- Heavy-Duty and Light-Weight
- 8" of space is required to replace or remove PC3
- 20/40 Combo slings have short wire rope legs for a 20' lift & four wire rope extensions w/shackles for the 40' lift.



**Note:** General - All Containers, Corner Fittings, and Sling Equipment shall be inspected for flaws and damage before use. Only equipment in good condition shall be lifted.

Proof Test Certificate is supplied with all slings.

#### Material and Finish:

- PC 1 - Steel, Painted
- PC 2 - Steel, Black
- PC 3 - Steel, Painted

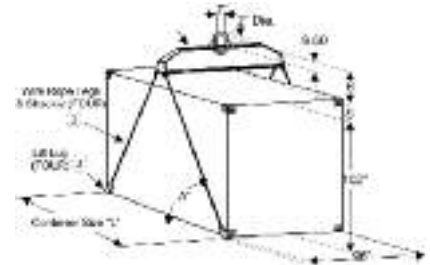

"L" Container Size (ft)	Order No.	Rated Work Load (lbs)	"H" Head Room (in)	"S" Slack (in)	Total Weight (lbs)	"A" Use Angle (°)
20'	416A00A-2PA	26,000	22.0	7"	434.9	45
20'	416A00A-4PA	52,900	27.5	12"	586.7	45
40'	416A00A-5PA	29,000	27.2	30"	552.9	30
40'	416A00A-6PA	67,200	33.1	30"	944.0	30
40'	416A00A-7PA	67,200	33.1	136"	934.0	45
20/40'	416A00A-9PA	67,200	33.1	12/30"	1004.0	45/30

"L" Container Size (ft)	Order No.	Component Part Numbers		
		PC1 Strongback Beam	PC2 Wire Rope Legs & Shackle	PC3 Lift Lug
20'	416A00A-2PA	41603AB-2PA	74016B-20/26.0	416000B-YPA
20'	416A00A-4PA	41603AB-4PA	74016B-20/44.8	416000B-YPA
40'	416A00A-5PA	41603AB-3PA	74016B-40/29.0	416000B-YPA
40'	416A00A-6PA	41603AB-5PA	74016B-40/67.2 L	416000B-YPA
40'	416A00A-7PA	41603AB-5PA	74016B-40/67.2 x 45	416000B-YPA
20/40'	416A00A-9PA	41603AB-5PA	74016B-20/40-67.2 L	416000B-YPA

## Economy Load-Leveling Bottom Lift Sling

### Order No. Q2500AA-400

#### Load Leveling:

For load leveling, adjust length of chain legs to shorten heavy end and lengthen legs on light end. Always leave slack in chain length that ends up between the two PC4 hooks to allow the two hooks to swing to their natural use angle. Adjust side to side leveling by moving PC7 toward heavy side.

Top Strongback can be adjusted longitudinally more than plus or minus 25% of container length from center line.

Slings also available for 20'

**Call for complete specifications**

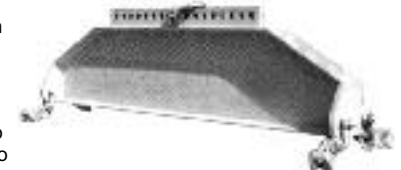

The Alloy Steel Top left Shackle has a stock Dia. of 1.50 and a 3.88" Inside Dia.

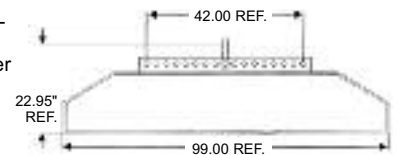

Order No.	WLL (Long Ton)	Wt. (lbs)
Q2500AA-400	30 LT	1440
Q2500AA-299 - 20' container sling also available		

**Below the Hook Lifting**

**Container Lifters/Vacuum Lifters**

**Two-Way Load Leveling Sling**

Available For Any ISO Container

New Sliding Shackle Design Saves Time When Adjusting!

After placing sling in position shown, insert rotary lugs into side holes of the four ISO 1161 Corner Fittings & Twist Lock. If center of gravity is known, unlock chain sprocket wheels and pull on the chain legs to be made longer.

Lock sprocket wheels when length desired is attained. The top shackle can be moved when it is not under load and is swung to horizontal. The action of swinging it back to vertical locks it for use. If center of gravity is not known, it must be determined by estimation and trial. Before lifting, rotary lugs and sprocket wheels must be locked in correct position.

Proof Tested and Certified

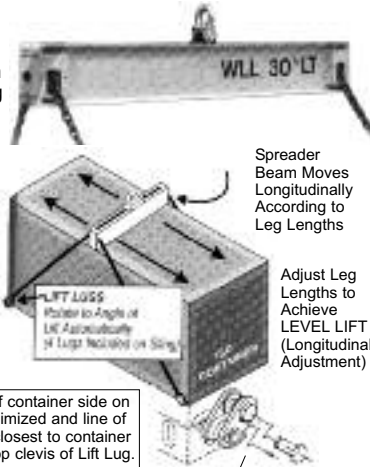

Model No.	Desc.	WLL (Long Ton)	Weight Each (lbs)
K1000AA-200	For 20 ft. (long)	30 LT	1520
K1000AA-300	For 40 ft. (long)	30 LT	1689

Longer opening available – call for details

**Top Lift Lug Assembly (Vertical Lift)**

The Most Specified Top Lift Lug!

**20901AA-1PA** - Complete Assembly with Master Link

**20901AA-2PA** - Without Master Link

**20901AA-4PA** - With Flex-Link for Angular Lifting of empty containers

- Remove jammed and damaged containers in cells
- Use as conventional lift for containers
- Lift pontoons with lift lugs in ISO type sockets

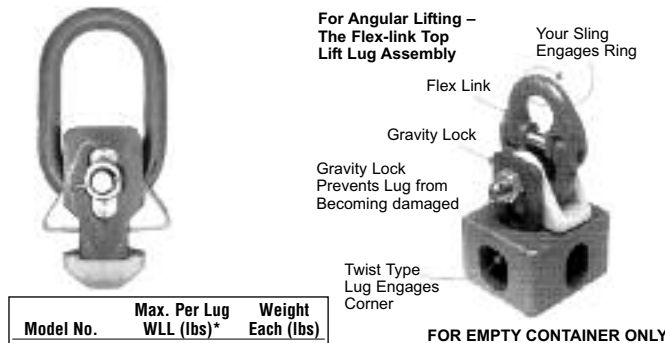

Model No.	Max. Per Lug WLL (lbs)*	Weight Each (lbs)
20901AA-1PA	25,000	30
20901AA-2PA	25,000	20
20901AA-4PA	25,000	30

**Rotating Lift Lug for Bottom Lifting**

**416000B-YPA**

- For Sling Angles From Vertical To 30 degrees
- Direct connection to sling wire - no shackle required.
- Fits Right or Left Hand Corner Fittings
- Painted Safety Yellow

Model No.	WLL (lbs)*	Wt. (lbs)
416000B-YPA	33,600	18.2

\* Set of 4 Required Per Container



**VACUUM LIFTERS**

**Technical & Operating Information**

CMCI Vacuum Lifters are of a modular design (most often configured from four components)

**Vacuum Power Pack**, is a self contained cabinet that mounts to the top of the load beam and is powered by either:

**Shop Air** (venturi unit)

- V-12 vacuum generator - operates on 80 PSI shop air, no electric service required. Explosion proof for hazardous applications.
- V-24 same specifications as V-12. Reduces attach time in larger capacity units.

**Electric Motor Driven Pumps**

- PUP-330 vacuum generator - 1/3 H.P., oil-less, 4 C.F.M., rotary vane pump, power supply - 115V, PH, 60HZ.
- PUP-1500 vacuum generator - 1-1/2 H.P., lubricated, 21 C.F.M., rotary vane pump, power supply - 230/460-3-60.
- PUP-1000 (optional D.C. power-consult factory), vacuum generator, 1 H.P., lubricated, 17 C.F.M., rotary vane pump, power supply - 230 D.C.

**Load Beam** is structural steel rectangular tubing, that also serves as a reserve tank on electric units. Lengths are available to meet your application.

**Cross Arm Beams** are structural channel and mount to load beam. Cross arm beams are adjustable for various size materials to be lifted.

**PADS** are available in different sizes (capacities) and material; **neoprene** - standard under +200°F, **silicone** - (200° to 600°F), and **mold on** (glass applications). Pad size (diameter of pad) and number of pads will determine capacity. Pad diameters range from 5" to 23".

**Standard Neoprene Pads**

Pad Code	S4	S6	V8	V10	V12	V16	V20
Pad Size Dia. (in.)	5	7-1/4	10-5/8	12-1/4	14-1/4	19	23

Silicone pads are the same size as neoprene.

**Standard Mold-On Pads**

Pad Code	M5	M8
Pad Size Dia. (in.)	6-7/8	9-1/4

**Features of Vacuum Lifters**

**ELECTRIC AND SHOP AIR (VENTURI) UNITS:**

- Standard units available to handle a wide range of material types, sizes, shapes and weights.
- Ball mounted vacuum pads.
- Brass fittings.
- Push lock hose (designed for 250 psi)
- Individual slide valve for each vacuum pad allows manual isolation of vacuum pads not needed for attachment.
- Muffler is spin on type for easy change out.

**ELECTRIC UNITS ONLY:**

- Vacuum reserve tank - maintains holding power temporarily in the event of a power failure.
- Push button 10' pendant and power plug to user power supply.
- Power cabinet has gull wing covers for easy access.
- Red/green indicator lites.
- Power supply available - 115 volt AC or 230/460 volt AC (DC available).
- Filter is spin on type for easy change out.
- Control valves are of the plug in type.
- Circuit breakers for electrical overload protection.

**SHOP AIR (VENTURI) UNITS ONLY:**

- Visual indicator gauges.

**INSPECTION**

The lifter should be visually inspected by or under the direction of an appointed person on a daily or weekly schedule depending on the nature of the lifter and the severity of the service.

Defects to look for include but are not limited to:

1. Structural deformation.
2. Cracks in the structural frame, welds, hoist hook attachment points, mechanically operating parts, and attached slings, clevises and hooks.
3. Wear of hoist hooking points, load supporting clevises, pins, slings, linkages and mechanical parts.

- continues -

13  
Below the Hook Lifting

# Vacuum Lifters

## Vacuum Lifters - Technical & Operating Information (continued)

4. Missing name plates and markings.
  - A. Daily: Perform filter and muffler check. Perform proof load test.
  - B. Weekly: Check seal rings, hoses and fittings. Check for loose bolts and nuts, as well as for structural dam-age. Test vacuum gauge reading. Test vacuum switch setting.
  - C. Quarterly: Clean vacuum pump. Check vacuum gauge. Check Red and Green indicator lights.

### OPERATING PRACTICES

1. The operator should watch carefully that the lifter is performing properly during the lifting procedure.
2. The operator should be familiar with the standard crane directing hand signals.
3. The operator should respond to signals from an appointed person only. However, stop signals from anyone shall be obeyed.
4. The operator should notify a designated person when he considers a load to be unsafe.
5. The operator should observe the lifter before using. A defect observed shall be examined by a qualified person to determine if it is a hazard.
6. Make sure proper electrical power or shop air supply is present.
7. Turn unit on, the red indicator light should light.
8. Position vacuum pads to support the load properly.
9. Make sure hand operated shut off valves are in proper position.
10. Lower unit onto load and activate Vacuum.
11. When Green light comes on lift load.

### HANDLING THE LOAD

1. The lifter should not be loaded in excess of its rated load.
2. The combined weight of the lifter and load should not exceed the rated load of the crane or hoist.
3. The lifter should be applied to the load in accordance with the manufacturer's recommended operating procedure.
4. The lifter should not touch obstructions during load movement.
5. The lifter should not be loaded with loose material that might fall during movement.
6. The operator or other personnel should not ride suspended loads or enter restricted spaces adjacent to them.
7. The operator or other personnel should not place themselves or any part of their bodies beneath suspended loads.
8. The load or lifter should not be used on the floor or other surface.
9. The lifter should not be used for loads for which it is not designed.
10. If suspended loads are moved manually, they should be pushed, not pulled.
11. A preliminary lift of a few inches should be made to establish that the load is stable.
12. All loads should be accelerated and decelerated smoothly.

## Index to CMCI Vacuum Lifters

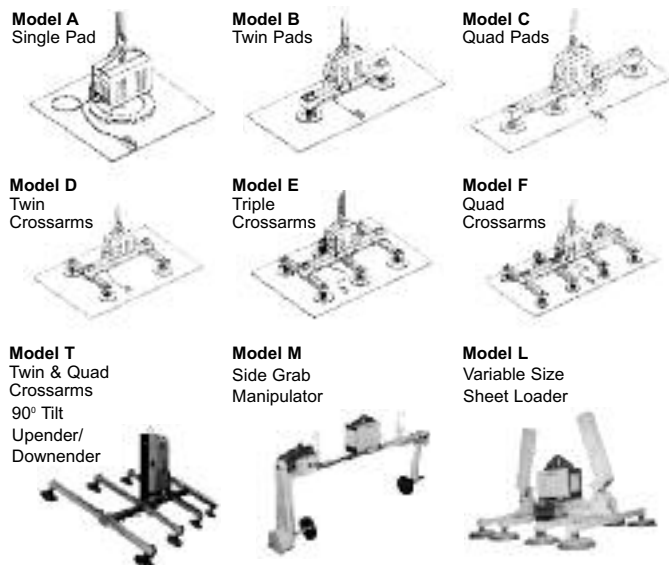

## Model Code Breakdown

Model Type	Vacuum Power	Capacity (lbs)	Pad Code	Load Beam Length (ft)	No. of Crossarm Beams	Crossarm Beam Length (ft)
A - F, T	A (Shop air) E (Electric)	Omit "00"	All standard pads are neoprene except model T for glass is mold on	4 - 20	D (two) T (three) Q (four) note: two pads per crossarm (standard)	3, 4 or 5

**Example** Model Number: D•E•12•V8•5•D•3

- D = Twin Crossed Arm w./4 pads
- E = Electric Power
- 12 = 1200 lbs. capacity
- V8 = Neoprene pad, 10-5/8" in diameter
- 5 = Load beam length 5 feet
- D = Two cross arms
- 3 = Cross arm beam length 3 feet

## Selection Guide

### Basic Configuration of Vacuum Lifters and their uses

**SINGLE PAD UNIT** - used to lift relatively small square sheets of a fairly rigid material. The operator must place the unit in the center of the load.

**MULTIPLE PAD IN-LINE UNIT** - used to lift rectangular sheets that tend to be fairly rigid and narrow in width.

**MULTIPLE PAD, MULTIPLE ROWS MOUNTED ON CROSS ARMS UNIT** used as most flexible lifter, for thin sheets where more support is required or very large lifts where support and capacity are required.

**Selection: Use size & weight of sheet.** If multiple sheets are to be lifted with the same lifter, make a calculation from a composite of the different sheets. Use the greatest width and length; and the thinness size. Choose a capacity greater than the heaviest sheet to be lifted.

### 1. INFORMATION REQUIRED

A. Material (TYPE)  
 Steel  Aluminum  Glass  Other  
(consult Hanes Supply)

B. Weight in lbs \_\_\_\_\_  
 C. Thickness (inches or gauge) \_\_\_\_\_  
 D. Width (inches) \_\_\_\_\_  
 E. Length (inches) \_\_\_\_\_  
 F. Power Available for vacuum lifter

Shop Air  Electric  230/460V  230V  
 80 PSI 115V AC DC

2. Using thickness and material type determine max. Overhang Distance\* from Overhang Distance Chart. \_\_\_\_\_

\*Overhang distance is the maximum distance between the edge of material and center of closest pad that will not cause a deflection (or droop) to exceed two (2) inches at any point on the load for safety reasons. The load should remain as flat as possible during the lift to prevent it from peeling away from the pads.

3. Use width & length to determine number of pads for sheet dimensions.  
 a. Divide width by 2 times the overhang distance. This will equal the number of pads in width dimension. (round up to nearest whole number).

$$\frac{\text{width}}{\text{overhang distance} \times 2} = \frac{\# \text{ pads}}{\text{width}}$$

b. Divide length by 2 times the overhang distance. This will equal the number of pads in length dimension (round up to nearest whole number),

$$\frac{\text{length}}{\text{overhang distance} \times 2} = \frac{\# \text{ pads}}{\text{length}}$$

C. The number of pads width & length give you a vacuum lifter configuration.

# pads width                      # pads length

\_\_\_\_\_ by \_\_\_\_\_  
 \*\*(either 1 or 2)                      \*\*(either 1, 2, 3 or 4)

\*\*Call factory if configuration does not meet standard # pads.

NOTE: Always space pads evenly along width and length to insure that

- continues -

**Below the Hook Lifting**

**Vacuum Lifters/Lifting Magnets**

**Vacuum Lifters - Selection Guide (continued)**

each pad will carry its share of the load.

4. Use sheet size and number of pads to determine load beam length and (if applicable) **crossarm beam length**.

a. Load beam length is sheet length divided by the # of pads in length dimension times # of pads in length minus 1.

$$\frac{\text{sheet length (in.)}}{\# \text{pads length}} = \frac{\text{Load Beam length}}{\# \text{pads length minus 1}} \times \text{min. 4'}$$

b. Crossarm beams (if applicable) is sheet width divided by the # of pads in width dimension times # of pads in width minus 1.

$$\frac{\text{sheet length (in.)}}{\# \text{pads width}} = \frac{\text{Crossarm beams length}}{\# \text{pads width minus 1}} \times \text{min. 3'}$$

5. Refer to the index on opposite page and match up your pad configuration with standard model.

6. At the model page:

- a. Select your power type. (Shop air - Venturi or Electric)
- b. Choose the capacity of the unit.
- c. For models B-F and T, model code needs beam lengths to complete.

NOTE:

- 1. **CAUTION:** DO NOT exceed rated capacity.
- 2. Check when using a single row of pads, load width should not exceed five (5) times the pads diameter (see specifications for pad diameter).
- 3. Call for more information on options as well as non-standard models.

**OVERHANG DISTANCE CHART**

Gauge or Thickness (in)	Decimal Equivalent	Max. Overhang Distance (in) for 2" Deflection	
		Steel & Alum.	Glass
26	.0179	14	7
24	.0239	17	8
22	.0299	19	9
20	.0359	20	10
18	.0478	24	12
16	.0598	26	13
14	.0747	30	15
13	.0897	32	16
12	.1096	35	17
11	.1196	37	18
1/8	.1250	38	19
10	.1345	40	20
8	.1644	44	22
7	.1793	46	23
3/16	.1875	47	23
1/4	.2500	54	27
5/16	.3125	60	30
3/8	.3750	66	33
7/16	.4375	72	36
1/2	.5000	77	38
9/16	.5625	81	40
5/8	.6250	86	43
11/16	.6875	90	45
3/4	.7500	94	47
7/8	.8750	101	50
1	1.000	108	54

**Advantages and Applications for Vacuum Lifters**

**Venturi (Shop Air)**

CMCI's Vacuum Lifters adhere to the highest quality standards in the industry. CMCI engineered its standard horizontal units to an industry leading 3 to 1 vacuum safety factor (5 to 1 on the structural components). On CMCI upenders/downenders the vacuum safety factor is 6 to 1 in the horizontal position and 3 to 1 in the vertical position. While CMCI has standard models, its engineers are always available to custom design a unit to your specific application... including pick and place automated transfer systems. All units conform to ASME B30.20 and OSHA standards.

- continues -

**Vacuum Lifters - Quality & Engineering in Every Lift (continued)**

CMCI Vacuum Lifters are designed for efficient one person operation in lifts of semi-porous and non-porous material. Vacuum units will not mark or scratch material surfaces or edges, as magnets and edge grabs will do

Additionally, CMCI vacuums will lift thin sheets (under 1/4") one at a time or nonferrous metals, unlike magnets.

Whenever materials need to be stacked, stored, loaded unloaded or transferred... think CMCI Vacuum Lifters.

**Vacuum Lifters**

- Increase productivity reducing cost.
- Are single operator run.
- Eliminate material damage.
- Make precision handling easy.
- Allow versatile handling of most materials.
- Improve storage space.
- Provide a low maintenance lifter.
- Increase safety to operator and machinery.
- Are durable for long lasting service.
- Have rated capacities and safety warnings displayed on both sides of equipment. Lettering is clearly visible from floor.
- Are registered with metal tags attached to each lifter.

**Air Powered**

**Venturi (Shop Air)**



**Electric Powered**

**115v or 230/460v**



**Industry users**

CMCI Vacuum Lifters are applicable to most industries. A short list of industries CMCI has served is primary metal, metal fabricators, aircraft, glass, plastics, automotive, paper, instruments, electrical equipment, construction machinery, and nuclear.

**Sheet Handlers**

- Handle sheets stacked horizontally or vertically.
- Increase production time.
- Protect workers from cuts, slivers, nicks, and burns.
- Handle steel sheets, plates, hot or oily parts.
- No electricity required.

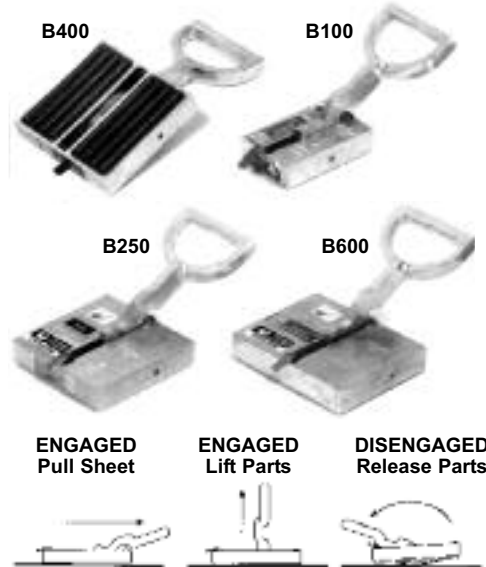

Part No.	Width (in)	Height (in)	Magnet Length (in)	Wt. (lbs)	Pickup (lbs)
B100	3-1/2	1-3/8	5	3.5	50
B250	6	1-3/8	6	6.75	125
B400	6	1-3/8	6	6.75	200
B600	6	1-3/8	7-1/4	8.25	300

Holding values are stated at 50% of the actual value.

## Lifting Magnets

### Conform-A-Lift

IMI's electromagnetic Conform-A-Lift is an ideal lifting device for odd or difficult shaped metal objects. The Conform-A-Lift is designed to automatically adjust its pole pieces to the shape of the part to be lifted.

Sprockets, gears, corrugated surfaces, domes, rebar bundles, etc., are no longer difficult to lift with a magnet. For simplified loading or unloading of bulk crates, handling steel items in receiving and shipping areas, and for fast transferring of steel sheets, plates, bar stock, angles and rounds, whatever the orientation of the part, use a Conform-A-Lift.

- Self adjusting magnetic poles to match part contour
- Strong 1" I.D. eye lug
- Long life welded stainless steel construction
- 12, 24 or 110 volt DC
- 6 foot cord

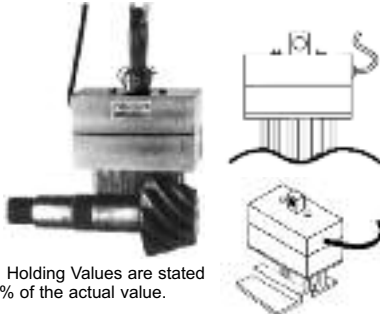

Note: Holding Values are stated at 50% of the actual value.

12 VDC Part No.	24 VDC Part No.	Height (in)	Width (in)	Length (in)	Weight (lbs)	Watts	Pickup (lbs.)
CL1-03X06E	CL2-03X06E	4	3-5/8	6-1/4	11	75	58
CL1-05X08E	CL2-05X08E	5	5	8-1/4	30	150	123
CL1-09X11E	CL2-09X11E	6	9	11-1/2	138	225	200
CL1-13X16E	CL2-13X16E	7	13	16-1/2	206	350	390

### Creative Lift

IMI's Permanent Creative Lift magnets are ideal for handling steel plate, forgings, die castings and similar items in machine shops, warehouses and industrial processing plants.

In the handling of thick, non-flexing ferrous items, IMI Creative Lift magnets eliminate the need for slings, clamping devices or chains. Time and labor savings are realized because one person can perform operations previously calling for two or more people.

IMI Creative Lift magnets are the proven solution to simplified machine loading and unloading, for handling steel items in receiving and shipping areas and the fast stacking, destacking and transfer of steel sheets, plates, bar stock, angles and rounds.

- No damaging parts
- Quick release - on/off
- Safety of permanent lift
- Strong eye bolt life

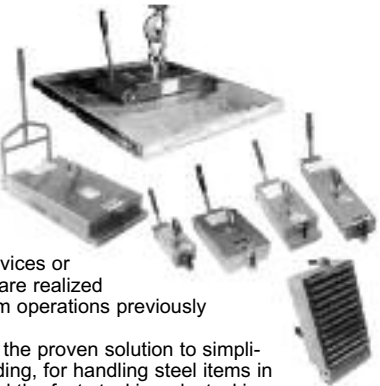

Part No.	Name	Height (in)	Width (in)	Length (in)	Weight (lbs)	Pickup (lbs.)
5C1382	Mighty Mite	2-11/16	3-1/2	6-1/2	12	400
5C1383	Junior	2-3/4	5	8-1/2	28	1,000
5C1384	Tuffy	2-3/4	6-1/2	10-1/2	42	1,500
5C1385	Long John	2-3/4	4-1/2	16	49	1,250
5C1386	Big Daddy	3-3/16	10	15-3/4	105	3,000

Note: Holding Values are stated at 50% of the actual value.

CAUTION: Never stand under load being lifted. Always use extra caution. Only use lifts on thick material that does not flex or bend.

### No-Mar Lifting

IMI's permanent NO-MAR lift magnets are ideal for handling steel plates, forgings, die castings, pipes and other thick non-flexing items, without marring the product surface.

When On, a magnetic field is driven down through the pole shoes for the lifting operation, and an automatic device locks the operating lever into place to prevent accidental deactivation.

When Off, the reversible core is rotated 180°, and the magnetic field is contained within itself, releasing the part. The rotating On/Off arm is mounted on ball bearings and has no physical contact during arm rotation.

- No damaging parts
- Permanent magnet
- Quick release - on/off
- No electricity needed
- Ideal for flat or round parts



Part No.	Overall Height (in)	Magnet Width (in)	Magnet Length (in)	Weight (lbs)	Pickup Capacity	
					Flat (lbs)	Round (lbs)
TPL0440	9-7/8	5-1/2	7-7/8	35	440	220
TPL1100	12-13/16	8-1/4	11	110	1,100	550
TPL2200	16-3/4	11-5/8	13-3/16	220	2,200	1,100
TPL4400	19-11/16	16-1/8	17-3/4	662	4,400	2,200

Note: Holding Values are stated at 50% of the actual value.

CAUTION: Never stand under load being lifted. Always use extra caution. Only use lifts on thick material that does not flex or bend.

### Permanent Lift Magnets for Flat Material Handling

#### CM-100, CM-800 Toters

The TOTER is a compact, self-contained, lifting magnet which uses permanent magnets that maintain holding power indefinitely.

Within the steel housing are powerful ceramic magnets whose field is controlled by the "on-off" position of the handle. Because no electric power is required, TOTERS can operate completely free of the restriction of power cords, and can be used where electric power is not readily available.

#### Standard Features

- High strength steel bail
- Operating mechanism moves on bearings for ease of operation
- Specially shaped pole shoes ensure the full magnetic field is directed into work piece
- Operating handle plunger must be fully depressed to prevent accidental operation
- Handle locks in "On or Off" positions to prevent unintentional operation
- Meets all the requirements of ANSI/ASME B30.20 (safety standard)
- Supplied with manual, pull test certificate, video, and safety poster.

#### Recommended Applications

Permanent lifting magnets require good surface conditions to achieve maximum lifting. The TOTER is ideally suited for in-plant handling, loading, and unloading machine tools, and is commonly found in industrial plants, machine shops and warehouses. When greater holding capacity is required, refer to our battery magnets or our circular electric magnets.

#### Rated Lift Capacity

The maximum rated lift is based upon lifting clean, smooth, flat, low-carbon steel plate, 1-1/2" or thicker with the full area of the magnet's lifting surface in contact with the load. Derating is required for plates with rust or scale, plates thinner than 1-1/2" and alloy steels. More detailed ratings are contained in the OPERATOR'S MANUAL AND SAFETY INSTRUCTIONS.



Model No.	L (in)	W (in)	Height to Crane Hook (in)	Net Wt. (lbs)	Ship Wt.	Performance Ratings on ANSI 1020 Steel Rated Lift (lbs)
CM-400	7.64	5.67	12.4	72.6	80	0-880
CM-800	10.95	7.56	15.55	169.4	175	0-1760

**Below the Hook Lifting**

**Lifting Magnets**

**Circular Electric Lift Magnets for Flat Material Handling**

**CER Series**

A CER magnet, pound for pound, is the least costly, but most powerful magnet available. Due to the deep penetration of the magnetic field, it is less susceptible to adverse surface conditions than any other self-contained magnet.

**Standard Features**

- High strength steel bail
- Recessed "ON-OFF-RELEASE" switch is protected against accidental operation
- Low-carbon steel body for maximum magnetic performance
- Heavy-duty, fully moisture-protected coils would for 50% duty cycle
- Operating light indicates "ON" condition of magnet
- Built-in solid state rectifier permits operation from 115 volt AC outlet
- Coiled cord and twist lock adapter for quick connection to AC supply
- Mating twist lock receptacle provided for your installation convenience

**Recommended Applications**

CER magnets are ideally suited for in-plant handling of steel plate, flat stock, castings, forgings, or machined components in all types of industrial plants, machine shops, and steel warehouses. Handling of loose parts such as nuts or bolts is also a popular application.

**Rated Lift Capacity**

The maximum rated lift is based upon lifting clean, smooth, flat, low-carbon steel plate of ample thickness with the full area of the magnet's lifting surface in contact with the load. Derating is required for plates with rust or scale, thin plates, and alloy steels. More detailed ratings are contained in the OPERATOR'S MANUAL AND SAFETY INSTRUCTIONS

Sizes available from 600 to 10,500 lbs. rated lift and from 5-1/8 to 20 inches diameter. Contact for detailed specs and pricing.



Model No.	Power Required @ 115/160 supply (watts)	Net Wt. (lbs)	Dia. A (in)	Height to Hook H2 (in)	Performance Ratings AISI 1020 Steel Rated Lift (lbs)
CER-5	62	23	5-1/8	9-3/4	0-600
CER-7	83	43	6-3/4	11-1/4	0-1,200
CER-9	135	94	9	11-3/4	0-2,400
CER-12	345	142	12	13-5/8	0-4,000
CER-16	545	320	16	14-1/2	0-7,250
CER-20	1,050	560	20	15	0-10,500

**Local and Cordless Remote Controlled Battery Powered Lift Magnets for Flat Material Handling**

**WBM-13, WBM-25, WBM-36, WBM-50**

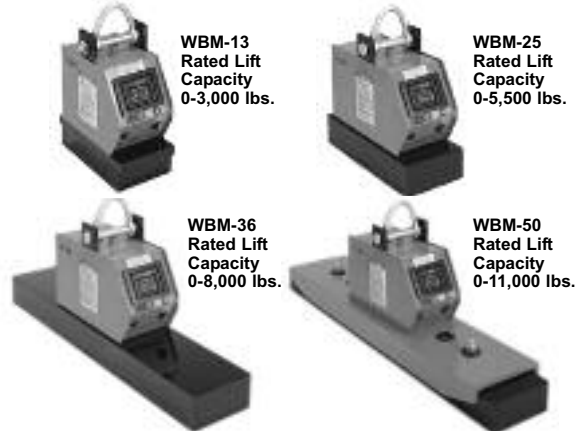

These Walker Lift Magnets are compact, mobile, self-contained battery powered units. Operating on their own power sources, they are free of restricting cords and wires and have the further advantage of being usable in areas where electric power is not available. The WBM-13 is a new, compact model for general utility lifting. The WBM-36 has a special shoe design for plate lifting, but it has almost universal capability. WBM-13, WBM-25 and WBM-36 are all single units. The WBM-50 is two magnets on an adjustable spreader beam operated from a single battery pack.

**Standard Features**

- Pocket for IR Remote Transmitter\*
- Removable cover allows inspection of battery.
- Temperature compensated: built-in automatic cut-off charger prevents over-charging of battery.
- For safety, magnet can not be turned "ON" if battery charge is too low.
- Interlock prevents magnet de-energization when suspended in air.
- Audible Warning Alarm and flashing light indicate low battery
- Lighted display indicates battery charge level.
- 110V AC cord and plug for built-in battery charger
- Uses "Deep Discharge" type low maintenance Gel Cell Battery.

**\*One IR Remote Transmitter Supplied with each WBM - WBP Magnet**

- Dual push button release
- Clip allows operator to attach to belt or pocket
- Single push button lift
- Additional remote control units available at nominal cost.



**Recommended Applications**

These versatile Walker magnets have widespread application for handling of plates, die blocks, machined components, smooth castings, and forgings. These Battery Powered Magnets are extremely useful throughout the plant - around the yard, receiving and shipping areas, storeroom, cut-off saws, burning and welding tables, and machine tools such as grinders, millers, shapers, drill presses, etc.

Batteries not included.

**Rated Lift Capacity**

The maximum rated lift is based upon lifting clean, smooth, flat, low-carbon steel plate, 2" or thicker with the full area of the magnet's lifting surface in contact with the load. Derating is required for plates with rust or scale, plates thinner than 2", and alloy steels. More detailed ratings are contained in the OPERATOR'S MANUAL AND SAFETY INSTRUCTIONS.

Model No.	Length (in)	Width (in)	Height to Crane Hook (in)	Net Wt. (lbs)	Ship Wt. (lbs)	Performance Rating on AISI 1020 Steel
WBM-13	16.3	8.6	22.4	165	175	0-3,000
WBM-25	21	9.6	22.6	295	310	0-5,500
WBM-36	48	9.6	22.8	530	550	0-8,000
WBM-50	60	12	23	640	690	0-11,000

## Lifting Magnets

### Local and Cordless Remote Controlled Bi-Polar Series Battery Powered Lift Magnets for Flat, Rounds and Shapes

#### WBP-7, WBP-15



WBP-7  
Rated Lift Capacity  
Rounds 0-1,665 lbs.



WBP-15  
Rated Lift Capacity  
Rounds 0-3,330 lbs.

The special feature of this Battery Bi-Polar Magnet is the unique design of pole shoe which enables it to handle a wide variety of structural shapes and rounds.

Powered by its own battery, it is free of restricting cords and wires, and can also operate in areas where electric power is not readily accessible.

**\*One IR Remote Transmitter Supplied with each WBM - WBP Magnet**

- Dual push button release
- Clip allows operator to attach to belt or pocket
- Single push button lift
- Additional remote control units available at nominal cost.



#### Recommended Applications

This unique magnet is ideally suited for handling pipe, tubing, bar stock, billets, I beams, H beams, angles, channels, Tees, Zees, and pilings. Although specially designed to handle structural shapes and rounds, the Bi-Polar configuration also lifts plate, forgings and castings.

Batteries not included.

#### Rated Lift Capacity:

The maximum rated lift is based upon lifting clean, smooth, flat, low-carbon steel, 2" or thicker with the magnet's lifting surface in full contact with the load. Derating is required for plates or other loads with rust or scale, loads thinner than 2" and alloy steels. Please consult the OPERATOR'S MANUAL AND SAFETY INSTRUCTIONS for more detailed ratings.

Model No.	Length (in)	Width (in)	Height to Hook (in)	Net Wt. (lbs)
WBP-7	18-1/2	9-1/2	27.8	370
WBP-15	30	10-1/2	30	736

The maximum rated lift is based upon lifting clean, smooth, flat, low-carbon steel, 2" or thicker with the magnet's lifting surface in full contact with the load. Derating is required for plates or other loads with rust or scale, loads thinner than 2" and alloy steels. Please consult the OPERATOR'S MANUAL AND SAFETY INSTRUCTIONS for more details.

### Material Lifting Magnets - Utilizing Neodymium Magnet Material

#### NEO-250, NEO-500, NEO-1000

The new NEO-250, NEO-500, NEO-1000 Series Material Lifting Magnets are used in steel supply, machine, and die shops where heavy steel objects must be moved rapidly and safely.

#### Features:

- High lift capacity
- Ease of operation
- Low weight... easy to move
- No power consumption
- Handle locks in "On or Off" positions to prevent unintentional operation
- Meets all the requirements of ANSI/ASME B30.20 (safety standard)
- Supplied with manual, pull test certificate, video and safety poster.



- continues -

#### Material Lifting Magnets -

#### Utilizing Neodymium Magnet Material (continued)

Model #	NEO-250	NEO-500	NEO-1000
Length (in)	5.94	9.69	12.44
Width (in)	3.94	4.72	5.79
Height (in)	4.06	4.06	4.88
Weight (lbs)	22	42	80
Cap. on Rounds (lbs)	0-275	0-550	0-1,100
Cap. on Plate (lbs)	0-550	0-1,100	0-2,200
<b>NEO-250</b>	Ideal for loads with a thickness of 1/4" or greater and diameters between 2 3/8" and 7".		
<b>NEO-500</b>	Ideal for loads with a thickness of 1/4" or greater and diameters between 2 3/4" and 10".		
<b>NEO-1000</b>	Ideal for loads with a thickness of 3/8" or greater and diameters between 3" and 11".		
<b>Performance Rating on AISI 1020 Steel</b>			

### Permanent Magnetic Lifting Magnets for Vertical Loading Onto Machine Centers and Lathes

#### NEO-HV Series

These NEOHV lifting magnets are designed to lift loads from the horizontal position into the vertical and vice-versa.

Imagine you have a plate lying on a pallet and you want to put it onto your horizontal machining center.

Operators have to do this many times a day and they usually have to struggle with clamps, slings or chains, often needing two people, to turn and keep the component in position.

Three standard models are available: NEOHV-250, NEOHV-500 & NEOHV-1000 with maximum lifting capacities of 550, 1100 and 2200 lbs. on flat AISI 1020 steel.

NEOHV lifting magnets are adjustable to accommodate a range of flat plates & flat circular disks.

Lifting arms, HV-250, HV-500 and HV-1000 can be purchased separately and retrofitted to a NEO-250, NEO-500 or NEO-1000 lifting magnet.

#### Standard Features

- Uses Standard NEO-250, NEO-500 or NEO-1000 lifting magnet
- Detachable lifting arm HV-250, HV-500 and HV-1000
- Meets all the requirements of ANSI/ASME B30.20 (safety standard)
- Supplied with manual, pull test certificate, video and safety poster.

#### Recommended Applications

The NEO series permanent lifting magnets requires good surface conditions to achieve maximum lifting capacity. Thanks to Neodymium magnets they perform quite well on flat non-machined surfaces with some rust or scale. The NEOHV model is ideally suited for in-plant handling, loading and unloading machine tools with a horizontal spindle and for plate handling in warehouses.

#### Workload Limit (Rated Lift Capacity)

The maximum lifting capacity is based upon lifting clean, smooth, flat, low-carbon (AISI 1020) steel plate, 3 inches or thicker with the full area of the magnet's poles in contact with the load. Derating is required for plates or flat material with rust or scale, non-machined or uneven surface, plates thinner than 3 inches and alloy steels. Refer to the operator's manual for more detailed workload limits.

Description	NEO-HV 250	NEO-HV 500	NEO-HV 1000	HV 250	HV 500	HV 1000
<b>Rated Lifting Capacity</b>	0 - 550	0-1100	0-2200	0-550	0-1100	0-2200
<b>Length (in)</b>	37.7	45.6	47.7	37.7	45.6	47.7
<b>Width (in)</b>	8.3	10.8	13.6	8.3	8.3	8.3
<b>Height (in)</b>	10 10	12.2	10	10	12.2	
<b>Weight (lbs)</b>	60	86	158	38	44	73
<b>Performance Rating on AISI 1020 Steel</b>						

**Below the Hook Lifting**

**Material Handling/Lifting**

**Flip-Rite™**

The FLIP-RITE™ Material Handling System allows you to raise, lower, rotate and level large, bulky or oddly-shaped objects up to 100 tons. The FLIP-RITE™ is engineered and built for optimal performance when attached to your crane hook. Each FLIP-RITE™ unit is custom-engineered to your application. It's the only way we work... it's the reason for our leadership in the field.

**Welding-Fabrication**

Engineered Systems Using the FLIP-RITE™ in a welding/fabrication environment increases the productivity, safety and quality of your workers' performance by providing a material handling system that positions the workpiece for efficient operations—at a greater

savings than a floor-mounted welding positioner.

FLIP-RITE™ allows the operator to position the piece in a way that may help reduce on the job injuries, and maximizes weld quality by allowing all welds to be made down-hand. And, with the 5-1 safety factor built into each FLIP-RITE™, operators' performance and comfort level increases with the knowledge that safety is the pivotal design element behind every system.

**Machining**

Machining operations reap much of the same benefits through the use of the FLIP-RITE™ system. The ability to handle and manipulate... raise, lower, level, and rotate any object... up to 100 tons, allows a never-before realized flexibility in the machine shop. A FLIP-RITE™ equipped

with the "powered leveling device" gives the operator full control over placing the workpiece on the machining bed.

Time saved in positioning can result in substantial dollar savings during the work week. Daily plans to handle workpieces are also minimized.

**Assembly & Manipulation**

The FLIP-RITE™ is an excellent tool for large assembly operation. With the FLIP-RITE™, positioning of workpieces is simplified for easy assembly, thus encouraging maximum productivity through safe handling.

ITNAC's experienced design staff can custom-tailor a FLIP-RITE™ to meet the needs of almost any assembly application.



13  
Below the Hook Lifting

**Man Cage**

Man Cages can be ordered in any size, shape or material to meet your specific applications. We also manufacture non-personnel, medical evacuation, and welding equipment Super cages. Ask about our Man Cage DFA (Direct Fixed Attached) personnel platforms (cages) which attach directly to the end of the boom on most cranes. DFA models do not require a bridle assembly or anti-two block device when used in this manner.

**Suspended Personnel Platforms**

CAUTION: Platforms are to be used only in compliance with federal rules and regulations.

The Man Cages are designed, engineered, manufactured, and certified to meet or exceed all existing Federal and State codes, Title 29CFR Part 1926.550(g), Crane and Derrick Suspended Personnel Platform. Inspection, load test and certification documents furnished.

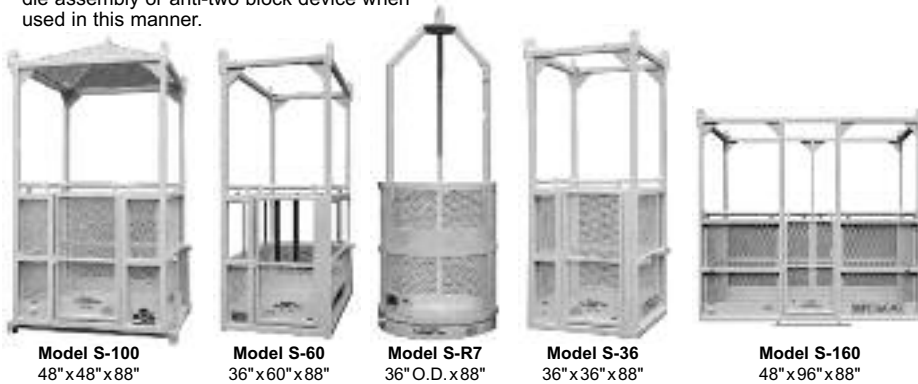

Model No.	Dimensions (in)			SWL* Capacity (lbs)	Test Wt. Optional (lbs)
	L	W	H		
S-30	30	30	44/88	500	625
S-36	36	36	44/88	750	938
S-50	36	48	44/88	750	938
S-60	36	60	44/88	750	938
S-75	48	48	44/88	750	938
S-100	48	48	44/88	1,000	1,250
S-125	48	54	44/88	1,250	1,563
S-150	48	60	44/88	1,500	1,875
S-160	48	96	44/88	1,500	1,875
S-170	48	108	44/88	1,500	1,875
S-200	48	72	44/88	2,000	2,500
S-400	72	144	44/88	4,000	5,000
S-1000	84	84	96	10,000	12,500
S-R5	18	DIA	88	300	375
S-R7	36	DIA	88	500	625
S-AL1	36	36	44/88	500	625
S-AL2	48	48	44/88	1,000	1,250
S-NP60	60	60	72	1,000	N/A
S-NP603	60	60	60	3,000	N/A

\*SWL = Safe Working Load

NOTE: 5 of the 20 available models shown here. Call Hanes Supply for more information regarding all your lifting needs.

**Load Indicator Devices**

**LLX Series w/Microprocessor - Dynafor®**

The new DYNAFOR® LLX range of load indicating devices are accurate, compact instruments for measuring tensile forces and loads. Designed for use on tough job site conditions, the DYNAFOR LLX load indicators can be used for the following applications:

- Avoiding the overload of man-riding platforms
- Under hook check weighing for mobile and overhead cranes
- Testing of material handling equipment
- On-hook weighing of goods during manufacturing
- Check weighing in shipping and receiving operations
- Weighing loads on multi-point lifts

**Technical Features**

- Lightweight aluminum alloy construction
- Microprocessor based operations
- Push-button operation and programming
- Automatic zero when unit turned on
- Multiple units of measure (Lbs., Tons, Metric Tonne, Kg, DaN, kaN)
- Output for display or connection to a personal computer

- Up to 7 DYNAFOR units may be connected to a personal computer at one time
- Ambient temperature range: -15°F to 120°F (-10°C to +50°C)
- Accuracy: ± 0.2% of capacity
- Up to 250 hours of operation with 3 AA alkaline batteries
- Auto shut-off for extended life
- Weatherproof and dust proof: IP 65

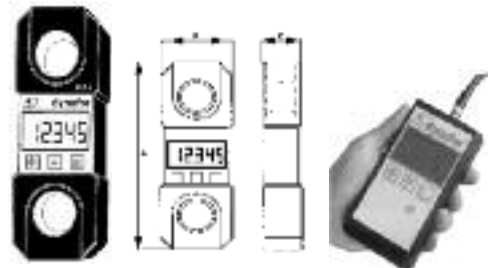

Model	Capacity (lbs)	Accuracy (lbs)	Smallest Load (lbs)	Max. Display	Dimension (AxBxC) (in)	Height of Digits (in)	Wt. (lbs)
LLX-.25	500	1	0.2	500.0	7.5 x 3.2 x 2.2	3/4	2.5
LLX-.50	1,000	2	0.5	1000.0	7.5 x 3.2 x 2.2	3/4	2.5
LLX-1.25	2,500	5	1	2500	7.5 x 3.2 x 2.2	3/4	2.5
LLX-2.5	5,000	10	2	5000	8.4 x 3.2 x 2.2	3/4	3
LLX-5	10,000	20	5	10000	9.2 x 3.5 x 2.2	3/4	4
LLX-12.5	25,000	50	10	25000	12.2 x 4.3 x 2.3	1	8.4
LLX-25	50,000	100	20	50000	14.1 x 5.3 x 2.7	1	14.5
LLX-50	100,000	200	10	10000	17.3 x 6.5 x 3.9	1	33
LLX-100	100T	0.2T	0.05T	100	26 x 10.2 x 4.7	1	101
LLX-250	250T	0.5T	0.1T	250.00	35.6 x 16.7 x 9.8	1-3/4	474

**Optional**  
Remote readout for LLX and MWX available  
• Hand held with .71 in. (LCD) digits



## Load Indicator Devices

### MWX Series w/Microprocessor - Dynafor®

The DYNAFOR MWX MINI WEIGHER range of load indicating devices with large 1-3/4" (44 mm) LCD are highly accurate instruments for load checking goods and materials, for check-weighing and measuring tensile forces. They are suitable for many check-weighing uses in industry, on job sites, in laboratories or on test benches.

The DYNAFOR principle is the movement of a material within its elastic limit, using bonded strain gauges to give an electrical signal under strain, relative to the load applied, and displayed on the LCD.

DYNAFOR the new shape of check-weighing and load measurement today!

DYNAFOR MWX MINI WEIGHERS: micro-processor based electronics with new standard functions and systems.

#### Functions:

- Operation and set up by 3 push button controls: ON/OFF, 100% tare, with return to total load applied, and peak hold, to show the maximum load applied.
- Up to 700 hours operation before battery change, with low battery indicator and auto-

matic shutdown after 20 minutes to save battery power.

- Choice of unit of measurement: kg, tonnes, lbs, short tons, daN or kN, displayed on the LCD.
  - Overload displayed to help prevent overloading the equipment and systems.
  - Automatic zero when switched on.
  - Output for connection to hand held display and controls, to P.C. or interface for processing or printing the information.
  - Variable response rate, to save battery power.
- Features:**
- Accuracy to ±0.2% of capacity.
  - Reliable operation, compact and rugged construction.
  - Ambient temperature range -14° F to +104° F

(-10° C to + 40° C).

- Weatherproof and dust-proof.
- Large top shackle and bottom hook.
- Lightweight aluminum alloy body.

#### Options:

- Model (MWX-IR) with infra red controls (OFF, tare, peak hold).
- Hand held display, with integrated push-button controls (ON/OFF, tare, peak hold).



Model	Capacity (lbs)	Accuracy (lbs)	Smallest Load (lbs)	Test Load (tons)	Max Display (lbs)	Height of Digits (in)	Wt. (lbs.)
MWX-2.5	5,000	10	2	5	5,000	1.75	15.43
MWX-5	10,000	20	5	10	10,000	1.75	18.74
MWX-12.5	25,500	50	10	25	25,000	1.75	46.29

Call for complete dimensional information.

### Model MSI-4300 Porta-Weight Plus

#### Standard Product Specifications

Accuracy: Plus or minus 0.1% of applied load

Display:

- 6 digit, 1.6 in./40 mm high numeric LCD (upper)
- 8 digit, 0.8 in./20 mm high numeric LCD (lower)
- Annunciators for measurement modes
- Photocell activated electroluminescent back-lighting

Filtering: Low, Medium or High selectable

Display Contrast: Adjustable

Pounds - Kilograms - Tons - Metric Tons: Switch selectable

Power: 8 disposable "D" size alkaline cells

Operating Time:

- Maximum 2000 hours (no backlight)
- Minimum 250 hours (operating time will vary with on/off duty cycle and with use of backlight)

Operating Temperature Range: 14° to +140° F (-10° to +60° C)

Enclosure: NEMA IV, alodined cast aluminum

Safe Overload: 200% of rated capacity

Ultimate Overload: 500% of rated capacity (except as noted)

Hook: Crosby thrust bearing swivel hook or equivalent

#### Standard Function Switches

POWER: Turns unit ON or OFF

ZERO: Zeros applied load up to 100% of capacity (limited range with NTEP or OIML option)

NET/GROSS: Switches unit between NET and GROSS

TARE: Tares applied load and displays weight in Net mode

TEST: Provides on-demand functional test

#### Optional 7 Key Configuration

Includes all of the above, plus:

TOTAL: Accumulates weighments (automatically or manually)

VIEW: Displays current total value

SETUP: Menu of selectable operating parameters (includes Set Points)

CLEAR: Dispose of previously entered values

SELECT: Controls menu of selectable parameters

ENTER: Entry of numeric values and selectable operating parameters

PEAK HOLD: Captures and holds maximum load

TARE MEMORY: Stores up to 10 tare values

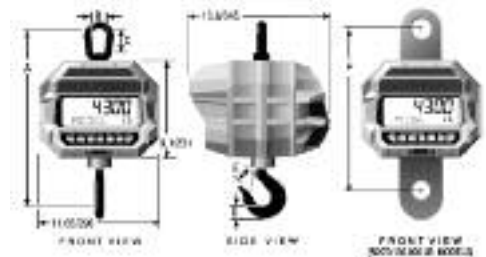

#### Options & Accessories

- 7 Key configuration
- NTEP and OIML approved for use in commercial trade (Contact factory for U.S. and International specs Class III & IIIL)
- Full function remote controller
- Substitute shackle for bottom swivel hook (possible headroom loss reduction)
- Oversized top lifting eye or shackle
- AC/DC input power 115/230 VAC and 12 - 250 VDC (Specify required voltage)
- RS232 data output
- Audible alarm

1. The MSI-4300 Porta-Weigh Plus crane scale is an ideal unit for heavy-duty applications in severe environments.
2. For heavy-duty applications requiring remote radio telemetry display and/or computer interface, MSI recommends specifying MSI-6260 Trans-Weigh.

Capacity		Resolution**		A*		B*		C*		D*		E*		F		Hook	Eye Nut or Shackle	Approx. Ship Wt.
(lbs)	(kg)	(lbs)	(kg)	(in)	(mm)	(in)	(mm)	(in)	(mm)	(in)	(mm)	(in)	(mm)	(in)	(mm)			
500	250	0.2	0.1	18.3	465	2.25	57.1	3.06	77.7	1.44	37.0	1.34	34.0	-	-	3 ton swivel	CR#7 Eye Nut	53 24
2,000	1,000	1	0.5	18.3	465	2.25	57.1	3.06	77.7	1.44	37.0	1.34	34.0	-	-	3 ton swivel	CR#7 Eye Nut	53 24
5,000	2,500	1	0.5	20.5	521	2.50	64.0	3.50	89.0	1.81	46.0	1.69	42.9	-	-	5 ton swivel	CR#8 Eye Nut	62 28
10,000	5,000	2	1	20.5	521	2.50	64.0	3.50	89.0	1.81	46.0	1.69	42.9	-	-	5 ton swivel	CR#8 Eye Nut	62 28
20,000	10,000	5	2	28.5	724	4.00	101.6	6.25	159	2.59	65.8	2.25	57.2	-	-	10 ton swivel	CR#11 Eye Nut	105 47
30,000	15,000	10	5	30.0	762	4.00	101.6	6.25	159	3.00	76.2	3.00	76.2	-	-	15 ton swivel	CR#11 Eye Nut	125 55
50,000	25,000	10	5	41.0	1041	5.00	127	6.00	152	3.66	93.0	3.63	92.0	15.0	381	25 ton swivel***	CR 25 ton Shackle #2130	235 106
70,000	35,000	20	10	43.2	1097	5.00	127	6.00	152	4.56	116	3.75	95.0	15.0	381	35 ton swivel****	CR 40 ton Shackle #2140	270 121
100,000	50,000	20	10	52.1	1324	5.75	146	6.65	169	5.06	129	4.25	108	16.25	413	CR 45 ton S1 Swivel*****	CR 50 ton Shackle #2140	420 189

CR = Crosby or equivalent.

\* These dimensions also apply to 50/70/100,000 lb. models with hook & shackles.

\*\* Resolution subject to change for NTEP & OIML approved units.

\*\*\* Ultimate overload - 490% of kg capacity.

\*\*\*\* Ultimate overload - 475% of lb capacity/430% of kg capacity.

\*\*\*\*\* Ultimate overload - 450% of kg capacity.

